

TECHNICAL MANUAL

**OPERATOR'S AND ORGANIZATIONAL MAINTENANCE MANUAL
INCLUDING REPAIR PARTS AND SPECIAL TOOLS LIST**

FOR

SEARCHLIGHT, INFRARED

AN/GSS-14(V)1 (NSN 5855-00-137-7697),

AN/GSS-14(V)2 (NSN 5855-00-137-7698),

AN/VSS-1(V)1 (NSN 5855-00-137-7696),

AN/VSS-1(V)2 (NSN 5855-00-137-8289)

WARNING

Do not turn off the main power switch until the blower has stopped.

Do not look directly into the searchlight when it is in operation. The high, intense, visible or infrared light may cause blindness or severe eye injury.

Do not operate the searchlight in the visible modes while personnel are within 200 meters of the beam path.

Personnel may suffer temporary flashblindness at ranges in excess of 200 meters when the searchlight is operated in either of the visible modes.

Be extremely careful when handling the high-pressure Xenon lamp. Avoid touching the quartz envelope of the Xenon lamp.

Change }
NO. 1 }

HEADQUARTERS
DEPARTMENT OF THE ARMY
Washington, DC, 26 February 1982

**OPERATOR'S AND ORGANIZATIONAL MAINTENANCE MANUAL
INCLUDING REPAIR PARTS AND SPECIAL TOOLS LISTS
FOR
SEARCHLIGHT, INFRARED
AN/GSS-14(V)1 (NSN 5855-00137-7697)
AN/GSS-14(V)2 (NSN 5855-00-137-7698)
AN/VSS-1(V)1 (NSN 5855-00-137.7696)
AN/VSS-1(V)2 (NSN 5855-00-137-8289)**

TM 11-5855-250-12&P, 26 May 1977, is changed as follows:

1. New or changed material is indicated by a vertical bar in the margin.
2. Added or revised illustrations are indicated by a vertical bar next to the figure number.
3. Remove and insert pages as indicated in the page list below:

<i>Remove pages</i>	<i>Insert pages</i>
i and iii.....	i and iii
4-3.....	4-3
None	4-4 through 4-6
A-1/(A-2 Blank)	A-1/(A-2 Blank)
C-3 through C-5	C-3 through C-6

4. File this change sheet in front of the publication for reference purposes.

By Order of the Secretary of the Army:

Official:

ROBERT M. JOYCE
Brigadier General, United States Army
The Adjutant General

E. C. MEYER
General, United States Army
Chief of Staff

Distribution:

To be distributed in accordance with Special List.



**OPERATOR'S AND ORGANIZATIONAL MAINTENANCE MANUAL
 INCLUDING REPAIR PARTS AND SPECIAL TOOLS LISTS
 FOR
 SEARCHLIGHT, INFRARED
 AN/GSS-14(V)1 (NSN 5855-00-137-7697)
 AN/GSS-14(V)2 (NSN 5855-00-137-7698)
 AN/VSS-1(V)1 (NSN 5855-00-137-7696)
 AN/VSS-1(V)2 (NSN 5855-00-137-8289)**

REPORTING ERRORS AND RECOMMENDING IMPROVEMENTS

You can help improve this manual. If you find any mistakes or if you know of a way to improve the procedures, please let us know. Mail your letter, DA Form 2028 (Recommended Changes to Publications and Blank Forms), or DA Form 2028-2 located in the back of this manual direct to Commander, US Army Communications-Electronics Command, ATTN: DRSEL-ME-MQ, Fort Monmouth, NJ 07703.

In either case, a reply will be furnished direct to you.

Table of Contents

		Paragraph	Page
Chapter	1. INTRODUCTION		
Section	I. General		
	Scope	1-1	1-1
	Index of technical publications	1-2	1-1
	Maintenance forms, records, and reports	1-3	1-1
	Administrative storage.....	1-4	1-1
	Reporting equipment improvement recommendations (EIR)	1-4.1	1-1
	Destruction of army electronics material	1-5	1-1
	II. Description and data		
	Purpose and use	1-6	1-1
	Tabulated data	1-7	1-3
	Items comprising an operable Searchlight, Infrared AN/CSS-14(V) and AN/VSS-1(V)	1-8	1-5
	Common names	1-9	1-6
	Description of equipment.	1-10	1-6
	Additional equipment required	1-11	1-8
	Searchlight configurations	1-12	1-9
	Differences in models.....	1-13	1-12
	III. Basic principles		
	General	1-14	1-12
	Equipment functioning.....	1-15	1-12
Chapter	2. INSTALLATION		
Section	I. Service upon receipt of equipment		
	Unpacking	2-1	2-1
	Checking unpacked equipment	2-2	2-1
	II. Installation instructions		
	General	2-3	2-1
	Servicing	2-4	2-1
Chapter	3. OPERATING INSTRUCTIONS		
Section	I. Controls and indicators		

Table of Contents con't.

		Paragraph	Page
	General	3-1	3-1
	Operator's controls and indicators.	3-2	3-1
	Blower inlet and outlet ports	3-3	3-2
	II. Operation under usual conditions		
	Starting procedures	3-4	3-3
	Standby procedure	3-5	3-4
	Normal stopping procedure	3-8	3-4
	Emergency stopping procedure	3-7	3-4
	III. Operation under unusual conditions		
	Fording	3-8	3-4
	Operation in arctic climate	3-9	3-5
	Operation in tropical climate	3-10	3-5
	Operation in desert climate	3-11	3-5
Chapter	4. OPERATOR AND ORGANIZATIONAL MAINTENANCE INSTRUCTIONS		
Section	I. Preventive maintenance		
	General	4-1	4-1
	Operator's weekly preventive maintenance	4-2	4-1
	Organizational monthly preventive maintenance	4-3	4-1
	II. Operator's preventive Maintenance		
	Scope of operator's maintenance	4-4	4-1
	Materials required for operator's maintenance	4-5	4-1
	Operator's weekly preventive maintenance checks and services	4-6	4-1
	Cleaning	4-7	4-2
	Operator's troubleshooting	4-8	4-2
	Conversion for travel	4-9	4-2
	III. Organizational preventive maintenance		
	Scope of organizational maintenance	4-10	4-2
	Materials required for organizational maintenance	4-11	4-2
	Organizational monthly preventive maintenance checks and service charts	4-12	4-2
	Organizational troubleshooting	4-13	4-3
	IV. Organizational support removal and replacement		
	General	4-14	4-5
	Replacement and repair techniques	4-15	4-5
	Disassembly and reassembly of shockmount assembly	4-18	4-5
Chapter	5. SHIPMENT, AND LIMITED STORAGE		
	Repackaging for shipment or limited storage	5-1	5-1
	Limited storage.....	5-2	5-1
			Illus
		Page	Fig.
Appendix	A REFERENCES.....	A-1	
Appendix	B BASIC ISSUE ITEMS LIST, ITEMS TROOP INSTALLED OR AUTHORIZED LIST, AND ORGANIZATIONAL MAINTENANCE REPAIR PARTS AND SPECIAL TOOLS LISTS		
Section	I. Introduction	B-1	
	II Basic issue items list	B-5	
	III Items troop installed or authorized list (Not applicable)		
	IV Repair parts list	B-6	
Group	00 Searchlight, Infrared AN/CSS-14(V)1, AN/GSS-14(V)2, AN/VSS-1(V)1, AN/VSS-(V)2	B-6	B-1
	01 Control, Searchlight C-7164/GSS-14(V) and C-7163/VSS-(IV)	B-6	B-1
	02 Mount, Searchlight MT-3900/GSS-14(V) and MT-3900A/GSS-14(V)	B-6	B-1
	0201 Yoke assembly (No parts authorized)		
	020101 Azimuth gear box assembly (No parts authorized)		
	020102 Brake assembly (No parts authorized)		
	02010201 Plate assembly (No parts authorized)		
	020103 Elevation gear box assembly (No parts authorized)		
	02010301 Plate assembly (No part authorized)		
	0202 Pedestal assembly MT-3900/GSSD14(V) and MT03900A/GSS-14(V)(No parts authorized)		
	0203 Shock absorber (No parts authorized)		
	0204 Bracket assembly (No parts authorized)		
	03 Shock mount assembly (No parts authorized)		
	0301 Coupler assembly, upper (No parts authorized)		
	0302 Coupler assembly, lower (No parts authorized)		
	04 Searchlight assembly	B-6	
	0401 Gear motor drive assembly (No parts authorized)		
	0402 Converter assembly, models 6484, 9912, 9924, 948, and F50001(No parts authorized)		

	0403 Cowling assembly	B-6	B-1
	0404 Heat exchanger (No parts authorized)		
	040401 Blower motor assembly (No parts authorized)		
	0405 Housing assembly (No parts authorized)		
	0406 Lamp housing assembly (No parts authorized)		
	0407 Igniter assembly (No parts authorized)		
	0408 Scope mount assembly (No parts authorized)		
	0409 Relay panel assembly, models 9913, and SC-D-613960 (No parts authorized)		
	0410 Switch assembly (No parts authorized)		
	05 180-ampere alternator kit (No parts authorized)		
	0501 Mounting kit (No parts authorized)		
	06 Cable assembly (No parts authorized)		
Section	V Special tools list (Not applicable)		
	VI National stock number and part number index (Not applicable)		
APPENDIX	C. MAINTENANCE ALLOCATION		
Section	I. Introduction	C-1	
	II. Maintenance allocation chart for Searchlight, Infrared AN/VSS1(V)1, AN/VSS-1(V)2, AN/GCSS-14(V)1, and AN/GSS-14(V)2	C-3	

LIST OF ILLUSTRATIONS

<i>Figure</i>	<i>Title</i>	<i>Page</i>
1-1	Searchlight, Infrared AN/VSS-1(V) (case not shown)	1-2
1-2	Searchlight, Infrared AN/VSS-1(V) (mounted on tank).....	1-2
1-3	Searchlight, Infrared AN/GSS-14(V) (mounted on jeep)	1-3
1-4	Searchlight, Infrared AN/GSS-14(V) (mounted on MT-3900A/GSS-14(V))	1-4
1-5	Searchlight, subassembly.....	1-7
1-6	Searchlight, subassembly (cowling assembly, primary reflector, xenon lamp, and upper elbow, removed).....	1-8
1-7	Control, Searchlight C-7163/VSS-1(V), front view.....	1-9
1-8	Control, Searchlight C-714/CG14(V), front view.....	1-10
1-9	Searchlight subassembly (cowling assembly removed) and tank power cable.....	1-11
1-10	Searchlight modes of operation	1-13
2-1	Typical packing of the AN/VSS-1(V).....	2-2
2-2	Typical packing of the AN/VSS-1(V), top cover removed.....	2-3
2-3	Typical packing of the AN/GSS-14(V)	2-4
2-4	Typical packing of the AN/GSS-14(V), top cover removed	2-5
3-1	Operator's controls and indicators (MT-3900A/GSS-14(V)).....	3-2
3-2	Location of blower inlet and outlet screens	3-3
4-1	Shockmount assembly, exploded view	4-1

CHAPTER 1 INTRODUCTION

Section I. GENERAL

1-1. Scope

a. This manual describes Searchlights, Infrared AN/GSS-14(V)1, AN/GSS-14(V)2, AN/VSS-1(V)1, and AN/VSS-1(V)2. It includes installation, operation, and operator and organizational maintenance. Also included, are operation under usual and unusual conditions, inspections, cleaning, and replacement of parts available to the operator and organizational maintenance personnel. Throughout this manual, the (V) after the type number, (for example, AN/GSS-14(V) and AN/VSS-1(V)) refers to both the (V)1 and (V)2, unless otherwise indicated.

b. Appendix A contains a list of publications applicable to the equipment, appendix B contains the repair parts list, and appendix C contains the maintenance allocation chart.

1-2. Indexes of Publications

a. *DA Pam 310-4*. Refer to the latest issue of DA Pam 310-4 to determine whether there are new editions, changes, or additional publications pertaining to the equipment.

b. *DA Pam 310-7*. Refer to DA Pam 310-7 to determine whether there are modification work orders (MWOs) pertaining to the equipment.

1-3. Forms and Records

a. *Reports of Maintenance and Unsatisfactory Equipment*. Maintenance forms, records, and reports which are to be used by maintenance personnel at all maintenance levels are listed in and prescribed by TM 38-750.

b. *Report of Packaging and Handling Deficiencies*. Fill out and forward DD Form 6 (Packaging Improvement Report) as prescribed in AR 700-581 NAVSUPINST 4030.29/AFR 71-13/MCO P4030.29A, and DSAR 4145.8.

c. *Discrepancy in Shipment Report (DISREP) (SF 361)*. Fill out and forward Discrepancy in Shipment Report (DISREP) (SF 361) as prescribed in AR 55-38/NAVSUPINST 4610.33A/AFR 75-18/MCO P4610.19B and DSAR 4500.15.

1-4. Administrative Storage

Administrative storage of equipment issued to and used by Army activities shall be in accordance with TM 740-90-1.

1-5. Destruction of Army Electronics Materiel

Instructions for destruction of Army electronics materiel to prevent enemy use shall be in accordance with TM 750-244-2.

Section II. DESCRIPTION AND DATA

1-6. Purpose and Use

The searchlight is a versatile, lightweight, mobile unit that provides a narrow or wide beam of high-intensity light in either the visible or infrared modes. When the searchlight is used in the infrared mode, an infrared (IR) filter is placed in the light path. The AN/GSS-14(V)1 and AN/VSS-1(V)1 use a black IR filter, which is used with IR viewing devices. The black filter emits a glow which may be visible out to 100 meters. The AN/GSS-14(V)2 and AN/VSS-1(V)2 use a pink IR filter, which can be used with IR viewing and image intensifying devices. The pink filter emits a glow which may be visible from 800 to 1000 meters. Temporarily overdriving the searchlight from 15

to 20 seconds provides a 50-percent increase in light intensity. The light emission can be interrupted without requiring power shutdown by operation of the searchlight in the blackout or standby condition. One searchlight has mounting hardware for use on tanks, and the other has a universal mount for use on jeeps and towers, as follows:

a. Searchlight, Infrared AN/VSS-1(V) is a tankmounted searchlight (fig. 1-1 and 1-2).

b. Searchlight, Infrared AN/GSS-14(V) is a universal-mounted searchlight (fig. 1-3 and 1-4) normally used on a jeep or tower.

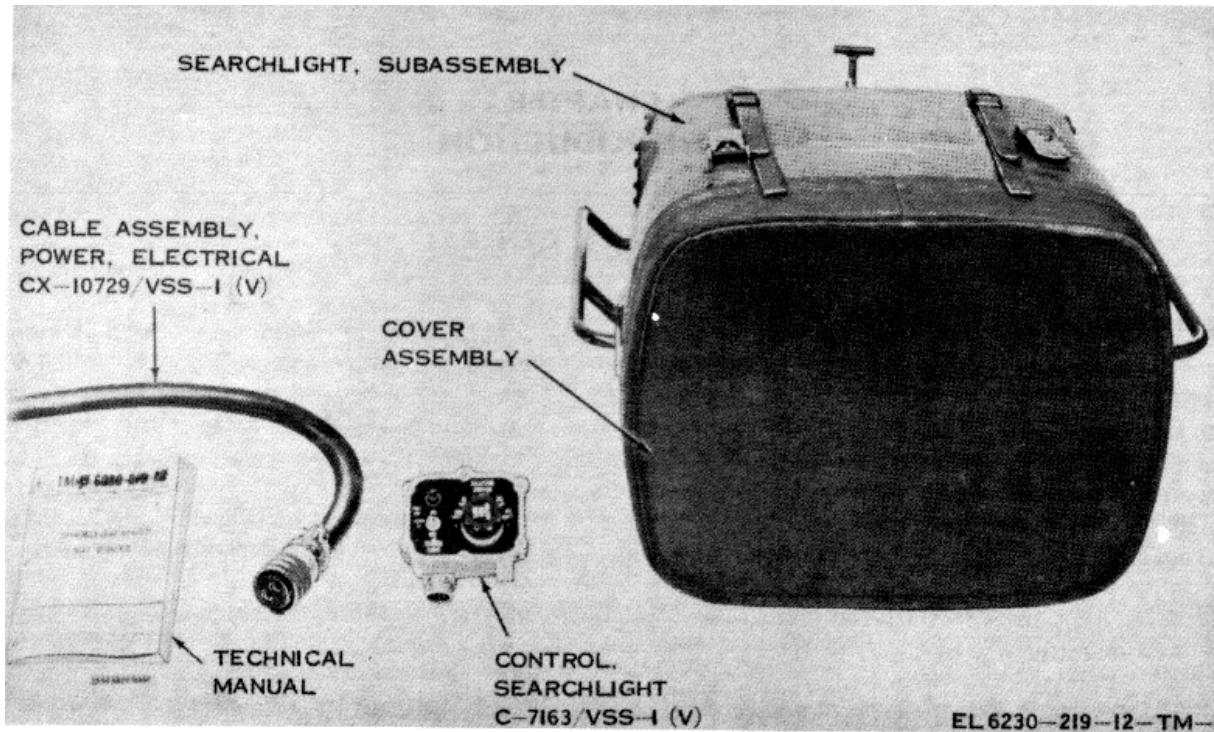

Figure 1-1. Searchlight, Infrared AN/VSS-1(V) (case not shown).

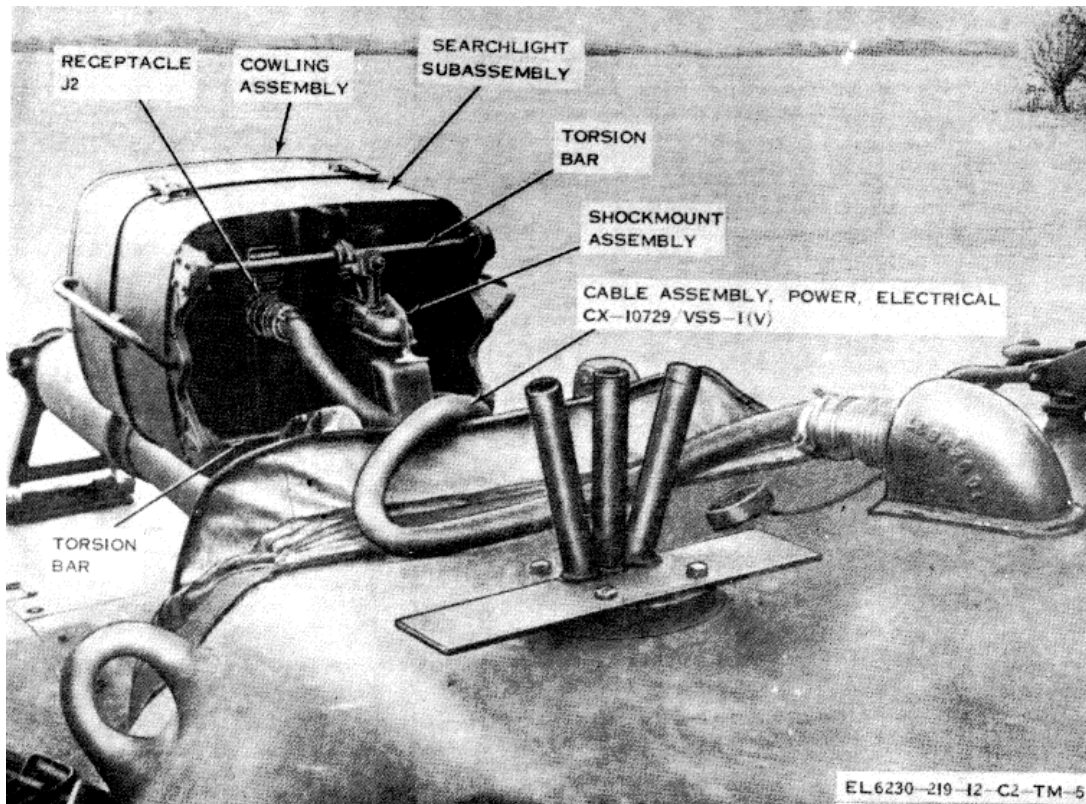

Figure 1-2. Searchlight, Infrared AN/VSS-1(V) (mounted on tank).

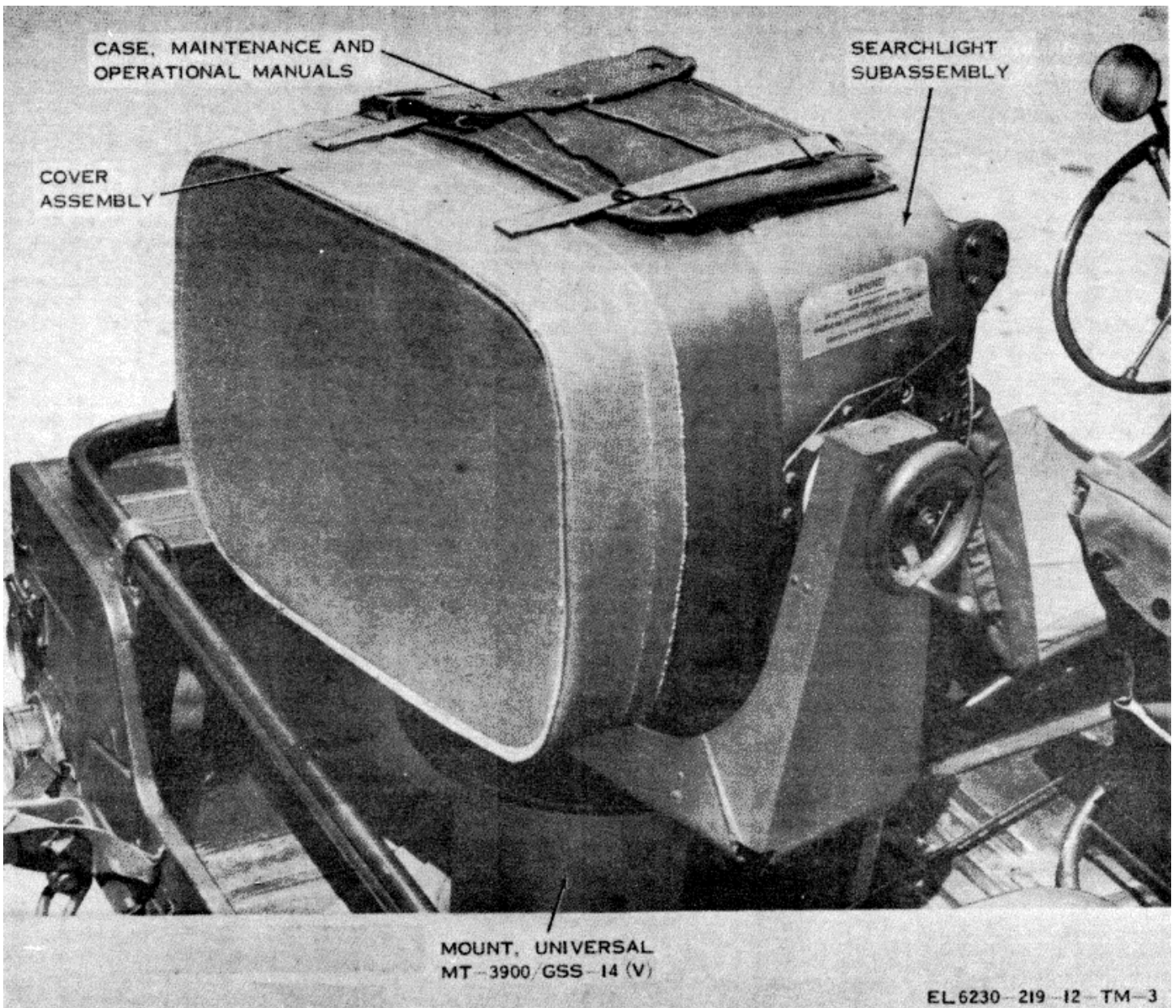

Figure 1-3. Searchlight, Infrared AN/GSS- 14(V) (mounted on jeep).

1-7. Tabulated Data

Type of light.....	Visible or infrared	Azimuth.....	to 6,500 mils.
Type of lamp.....	Xenon, short arc	Elevation	- 700 to + 1,400 mils.
Output candlepower:		Reduction drive (MT-3900A/GSS-14(V)):	
Normal.....	100 million	Azimuth.....	20:1.
Overdrive.....	150 million	Elevation	40:1.
Beamwidth:		Input power requirements:	
Narrow.....	0.5° to 0.75°	Voltage.....	28 volts dc.
Wide	7.0°	Current:	
Scan limits (MT-3900A/GSS- 14 and MT-39001GSS-14(V)):		Nominal.....	100 amperes.
		Overdrive	140 amperes.

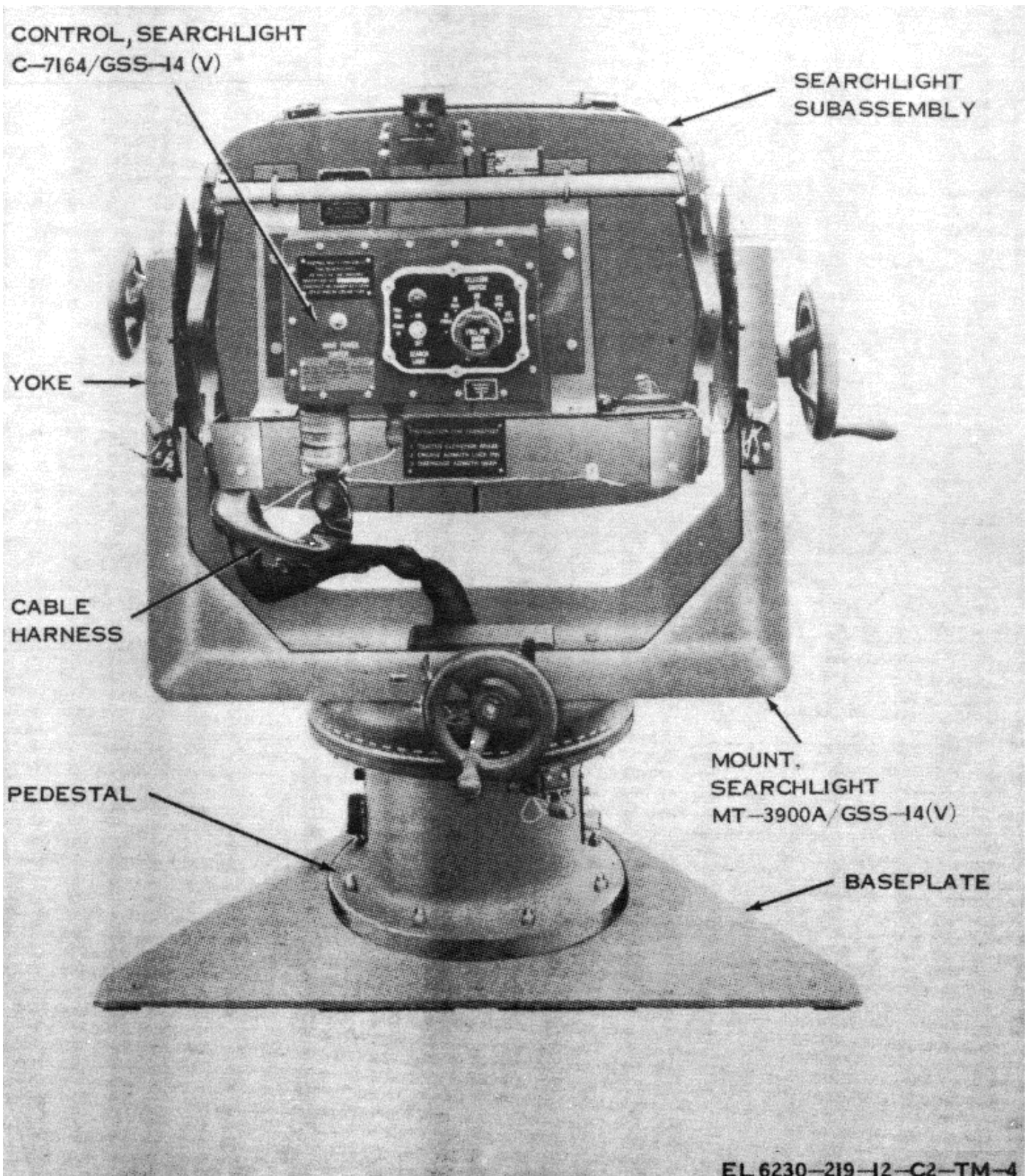

Figure 1-4. Searchlight, Infrared AN/GSS-14(V)(mounted on MT-3900A/GSS-14(V).

1-8. Items Comprising an Operable Searchlight, Infrared AN/GSS-14(V) and AN/VSS-1 (V)

Item	NSN	Qty	Dimensions (in)			Weight (lb)
			Height	Depth	Width	
Searchlight, Infrared AN/VSS- (V)1 consisting of:	5855-00-137-7696	1	20-1/2	31-1/2	30-3/4	230
Searchlight subassembly		1	20-1/2	31-1/2	30-3/4	230
Control, Searchlight C-7163/VSS- 1(V)	5855-00-014-5008	1	5-1/2	6-1/4	5-3/4	3-3/4
Cable Assembly, Power, Electrical CX- 10729/VSS-1(V)	5995-00-134-7165	1	95			12
Searchlight, Infrared AN/VSS- (V)2 consisting of:	5855-00-137-8289	1	20-1/2	31-1/2	30-3/4	230
Searchlight subassembly		1	20-1/2	31-1/2	30-3/4	230
Control, Searchlight C-7163/VSS-1(V)	5855-00-014-5008	1	5-1/2	6-1/4	5-3/4	3-3/4
Cable Assembly, Power, Electrical CX-10729/VSS-1(V)	5985-00-134-7165	1	95			12
Searchlight, Infrared AN/GSS- 14(V)1 consisting of:	5855-00-137-7697					
Searchlight subassembly		1	21-1/4	22-1/2	25-1/2	185
Control, Searchlight C-7164/GSS- 14(V) and one of the two following mounts and cables:	5855-00-933-4411	1	7-1/4	7-1/2	14-1/2	16
Mount, Searchlight MT-3900/GSS-14(V)	5855-00-087-1539	1	38-1/4	23	34	214
Used with but not part of:						
Cable assembly, power, electrical.	5855-00-087-1571	1	112			8 1/2
Cable assembly, power, electrical.	6150-00-179-8369	1	100 ft lg			100
Cable assembly, power, electrical.	6150-00-179-8370	1	50 ft lg			50
Mount, Searchlight MT-3900A/GSS-14(V).	5885-00-790-7218					
Used with but not part of:						
Cable assembly, power, electrical.	5995-00-119-1194	1	89			6-1/2
Cable assembly, power, electrical.	5995-00-179-8369	1	100 ft lg			100
Cable assembly, power, electrical.	5995-00-179-8370	1	50 ft lg			50
Searchlight, Infrared AN/GSS- 14(V) 2 consisting of:	5855-00-137-7698					
Searchlight subassembly		1	21-1/4	22-1/2	25-1/2	185
Control, Searchlight C-7164/GSS-14(V) and one of the two following mounts and cables:	5855-00-933-4411	1	7-1/4	7-1/2	14-1/2	16
Mount, Searchlight MT-3900/GSS-14(V).	5855-00-087-1539	1	38-1/4	23	34	214
Used with but not part of:						
Cable assembly, power, electrical.	5855-00-087-1571	1	112			8-1/2
Cable assembly, power, electrical	6150-00-179-8369	1	100 ft lg			100
Cable assembly, power, electrical.	6150-00-179-8370	1	50 ft lg			50
Mount, Searchlight MT-3900A/GSS- 14(V).	5855-00-790-7218	1	38-1/4	23	39-1/4	219
Used with but not part of:						
Cable assembly, power, electrical.	5995-00-119-1194	1	89			6-1/2
Cable assembly, power, electrical.	5995-00-179-8369	1	100 ft lg			100
Cable assembly, power, electrical.	5995-00-179-8370	1	50 ft lg			50

1-9. Common Names

A list of the nomenclature and common name assignments for the searchlight are given in the chart below:

Common name	Nomenclature
Searchlight	Searchlight, Infrared AN/VSS- (V) or AN/GSS-14(V).
Control box	Control, Searchlight C-7164/GSS- 14(V)
Tank control box	Control, Searchlight C-7163/VSS-1(V)
Tank power cable	Cable Assembly, Power, Electrical CX-10729/VSS-1(V).

1-10. Description of Equipment

The searchlight consists of two major operating units: the searchlight subassembly and a control box. Included is a canvas case for the protection and storage of technical manuals. Some searchlight applications include a shock-mount assembly, a jeep or tower mount, and power cables (para 1-8). A suitable power source is required for operation.

a. Searchlight Subassembly (fig. 1-5 and 1-6). The searchlight subassembly consists of the searchlight housing assembly which contains the greater part of the searchlight components; the cowling assembly, which contains the cowling glass; and the cover assembly (fig. 1-1) which protects the cowling assembly. The searchlight subassembly provides for the various mounting applications, component or cable connections, and protects the internal components from physical damage and exposure to dust and moisture.

(1) *Searchlight housing assembly* (fig. 1-6). This unit consists of the searchlight housing and internal components as described below.

(a) The cast aluminum searchlight housing forms the base for attaching the internal components, various type mounts, cable connection and, along with the cowling assembly, protects the internal components from physical damage and exposure to dust and dirt.

(b) The lamp housing assembly, mounted between the upper and lower elbows of the blower system, consists of the xenon lamp, the infrared filter, the blackout shield, the refractor lens, and lamp housing drive gears. Some lamp housing assemblies may contain a secondary reflector and a clear lens. The source and type of light (visible or infrared) originate at this point.

(c) The lamp cover, located in front of the lamp housing assembly, acts as a light shield to insure that all the light from the xenon lamp is directed toward the primary reflector and prevents light leakage during the blackout or standby mode of operation.

(d) The lamp drive assembly consists of three drive motors, three fuses, and six limit switches. The drive motors, mounted on the lower elbow in front of the lamp housing assembly, change the position of the infrared filter, the blackout shield, and the refractor lens, and thereby change the mode of operation as selected

by the operator. The limit switches stop the drive motors when the infrared filter, the blackout shield, and the refractor lens have reached the proper position. The fuses protect the drive motors from burnout.

(e) The primary reflector, located directly behind the limit switches, is used to shape and reflect the light produced by the xenon lamp.

(f) The heat exchanger assembly (fig. 1-6) is mounted on the left side of the searchlight housing assembly. The blower assembly circulates the air through the lamp housing assembly to cool the xenon lamp and prevent hot lamp explosion. Air drawn by the blower motor through the blower inlet screen passes through the heat exchanger assembly and is expelled through the blower outlet screen at the bottom of the searchlight housing assembly. If necessary, blower operation will continue after the searchlight power has been shut off to insure proper cooling of the xenon lamp.

(g) The converter assembly (fig. 1-6), mounted in the lower right portion of the searchlight housing assembly, provides alternating-current (ac) and direct current (dc) output voltages to the igniter assembly for xenon lamp ignition.

(h) The igniter assembly (fig. 1-6), mounted in the upper right portion of the searchlight housing assembly, provides radio frequency (rf) and dc voltages necessary to ignite and light the xenon lamp.

(i) The relay panel assembly (fig. 1-6), mounted directly below the igniter assembly, provides the switching action for changing the searchlight modes of operation, and the timing sequences for ignition and overdrive of the xenon lamp.

(j) The components of the input filter circuit are located in a shielded filter box on the right side of the searchlight housing assembly to which the relay panel assembly is attached. This circuit, in conjunction with ground straps and shielded wires, reduces the effect of rf interference during searchlight operation.

(2) *Cowling assembly* (fig. 1-5). This unit, which contains the cowling glass, is the front half of the searchlight. It is attached to the searchlight housing assembly by four latches and, along with the searchlight housing assembly, protects the internal components of the searchlight from physical damage and exposure to dust and moisture.

(3) *Cover assembly* (fig. 1-3). This canvas cover is placed over the cowling assembly and strapped to the searchlight. It protects the cowling glass from damage and an accumulation of dirt, ice, or snow when the searchlight is not in operation.

b. Control Boxes. These units contain the necessary switches and controls for the operation and control of the searchlight. Control, Searchlight C7163/

/VSS-1(V) (fig. 1-7), mounted within the tank turret, contains an indicator light, a SEARCHLIGHT power switch, and a mode SELECTOR SWITCH. The indicator light provides the operator with information concerning the operational status of the searchlight. Control, Searchlight C-7164/GSS-14(V) (fig. 1-8) is connected direct to the rear of the searchlight subassembly and contains the indicator light, the SEARCHLIGHT power switch, the mode SELECTOR SWITCH, a main power switch, and an override switch.

c. *Cables.* The tank-mounted searchlights use the tank power cable (fig. 1-2 and 1-9) to connect the

searchlight subassembly to the tank turret. Additional cables (not supplied with the searchlight) within the tank turret are used to complete the connection of the searchlight subassembly to the tank control box and input power. The AN/GSS-14(V)1 does not require interconnecting cables, because the control box is directly connected to the receptacle at the rear of the searchlight (fig. 1-8).

d. *Mounts.*

- (1) The AN/VSS-1(V) mounting is part of the

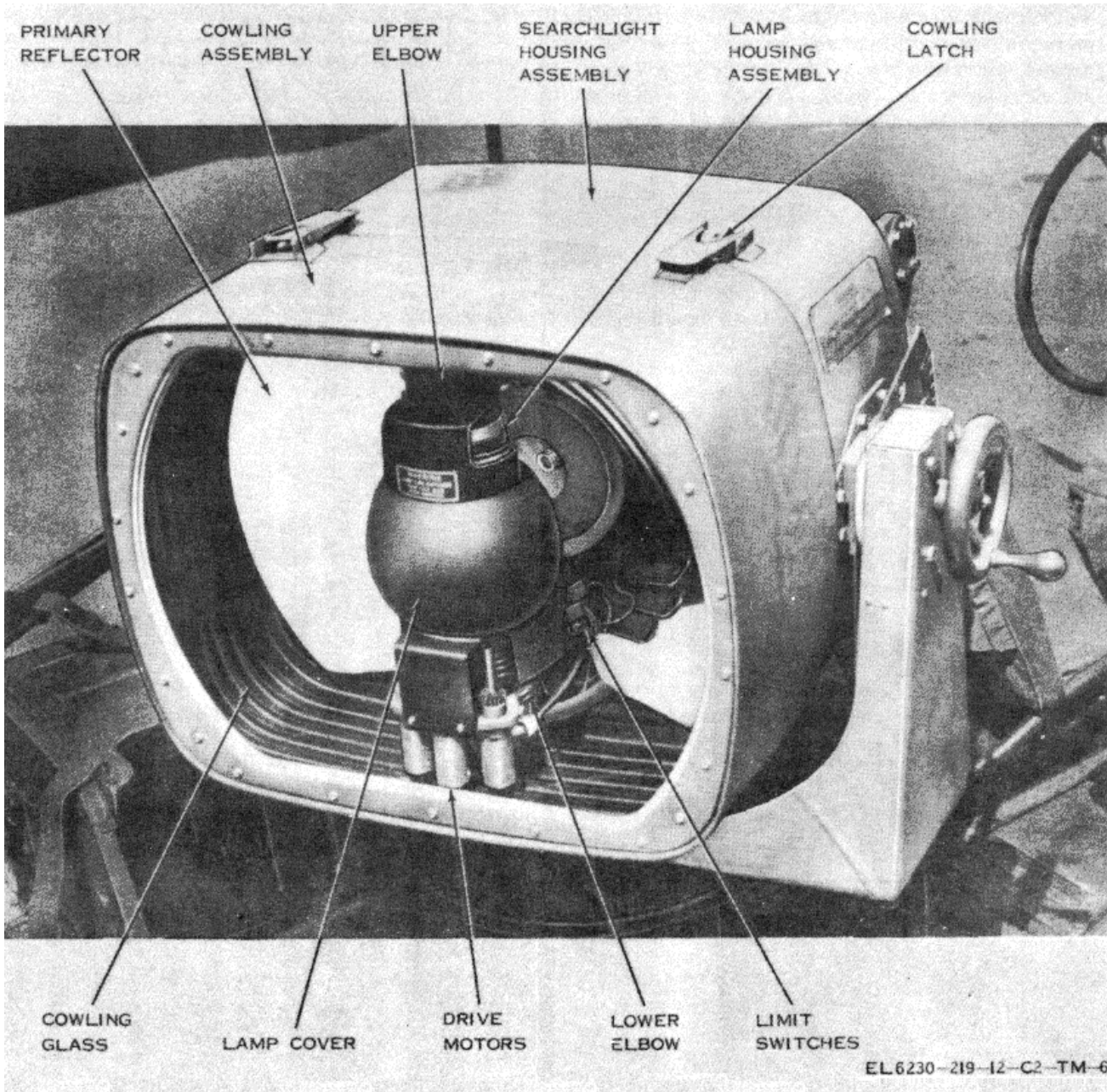

Figure 1-5. Searchlight, subassembly.

tank. The searchlight is equipped with a shock-mount assembly (fig. 1-2 and 1-9) which is part of the searchlight subassembly. The shockmount assembly consists of three ball-socket hitches, for mounting the searchlight subassembly to the tank, and two torsion bars which protect the searchlight subassembly from excessive stresses during gunfire.

(2) Two mounts are used with the AN/GSS-14(V), as follows:

(a) the MT-3900/GSS-14(V) used with the searchlight (fig. 1-3), consists of a yoke, to which the searchlight is attached, and a pedestal. The yoke is attached to the pedestal through a bearing assembly which enables the searchlight to turn in azimuth. The searchlight can be tilted in elevation by loosening the manual brake wheels at the end of the yoke. Azimuth and elevation scales have been added for operator use.

(b) The MT-3900A/GSS-14(V) (fig. 1-4), consists of a yoke, a pedestal, a baseplate, and a cable harness. The yoke supports the searchlight and

contains the manually operated elevation and azimuth mechanical drive systems used for directing the searchlight beam. The yoke is attached to the pedestal through a bearing assembly which enables the searchlight to be rotated to desired azimuth. Azimuth and elevation scales, illuminated by indicator lights, have been added for operator use. The pedestal supports the yoke and contains receptacles for connecting the searchlight to the input power cables. It also contains a switch and fuse to control and protect the azimuth and elevation scale indicator lights. The pedestal is attached to the baseplate, which is bolted to a tower, jeep, or similar vehicle.

1-11. Additional Equipment Required

a. A 28-volt dc, 150-ampere (minimum) power source is needed for operation but is not supplied with (or as part of) the searchlight. The same power source

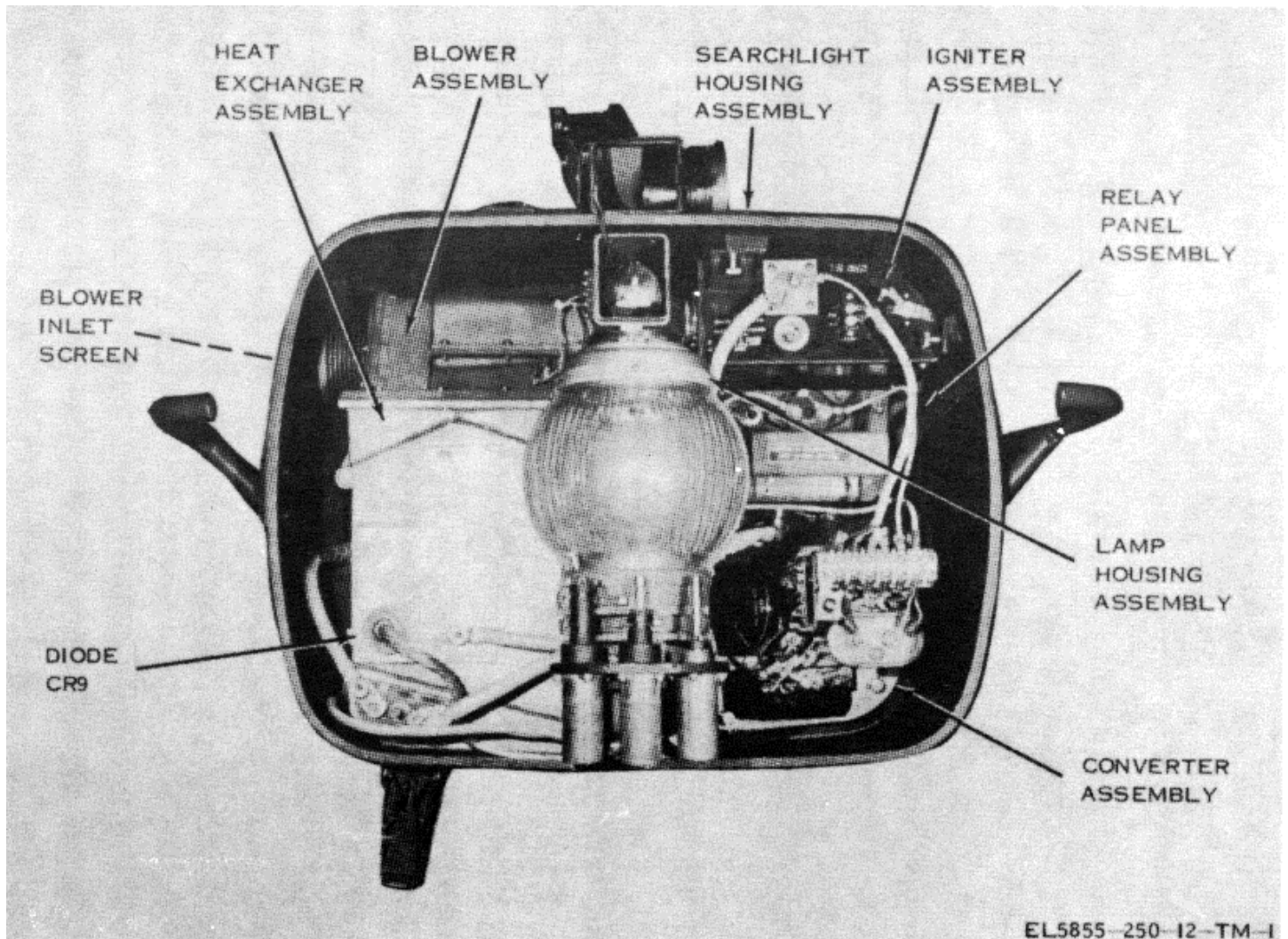

Figure 1-6. Searchlight, subassembly (cowling assembly, primary reflector, xenon lamp, and upper elbow, removed).

also supplies 28 volts dc, 1.5 amperes for the MT-3900A/GSS-14(V). The power source will be determined by the searchlight application.

b. Cables used with, but not part of the AN/GSS-14(V), are given below:

(1) MT-3900/GSS-14(V) uses cable assembly, power, electrical (NSN 5855-00-087-1571), 9 feet 4 inches.

(2) MT-3900A/GSS-14(V) uses cable assembly, special purpose, electrical, branched (NSN 5995-00-119-1194), 7 feet 9 inches.

c. Cables used with the tower but not part of the AN/GSS-14(V) are given below.

(1) Cable assembly, power, electrical (NSN 6150-00-179-8369), 100 feet.

(2) Cable assembly, power, electrical (NSN 6150-00-179-8370), 50 feet.

1-12. Searchlight Configurations

The nomenclature of each searchlight configuration, and the components originally equipped in each searchlight,

are listed in d below. In some instances, the originally equipped component can be replaced by a similar, but different, model component; however, the searchlight nomenclature will not change. The components most likely to be affected are as follows:

a. *Converter Assembly.* All models are interchangeable. When models 9912, 9924, and F50001 become unrepairable and replacement converter assemblies of these models are unavailable, model 6484 or 9948 will replace them. No other changes are required.

b. *Igniter Assembly.* Both models 9911 and F50006 are directly interchangeable.

c. *Relay Panel Assembly.* Model 9913, used in some searchlights, is not interchangeable with model SC-D-613960 and must be repaired. When relay panel assembly model 9913 cannot be repaired, the searchlight must be sent to depot for repairs.

d. *Possible Configurations.* Each searchlight will include one item from each column.

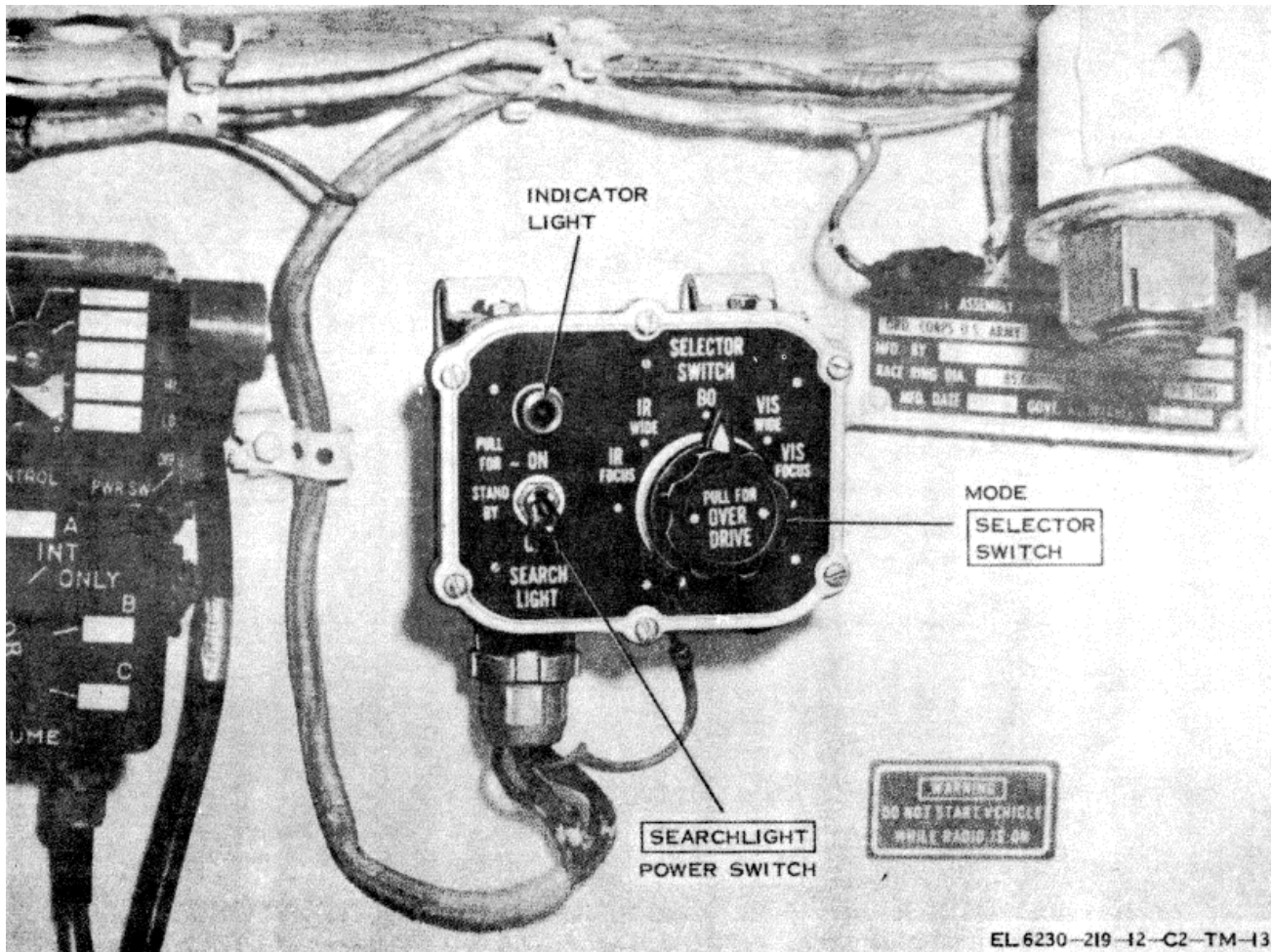

Figure 1-7. Control, Searchlight C-7163/VSS-1(V), front view.

Search subassembly				Control box	
Model	Converter assembly	Igniter assembly	Relay panel assembly	Control searchlight	Mount searchlight
AN/GSS-14(V)	9948 or 6484	9911	9922	C-7164/GSS-14(V)	MT-3900/GSS- 14(V) or MT-3900A/GSS-14(V)
AN/VSS-1(V)	6484 or 9912 or 9924 or 9948 or F50001	9911 or F50006	9913 or SC-D-61360	C-7163/VSS-1(V)	N/A

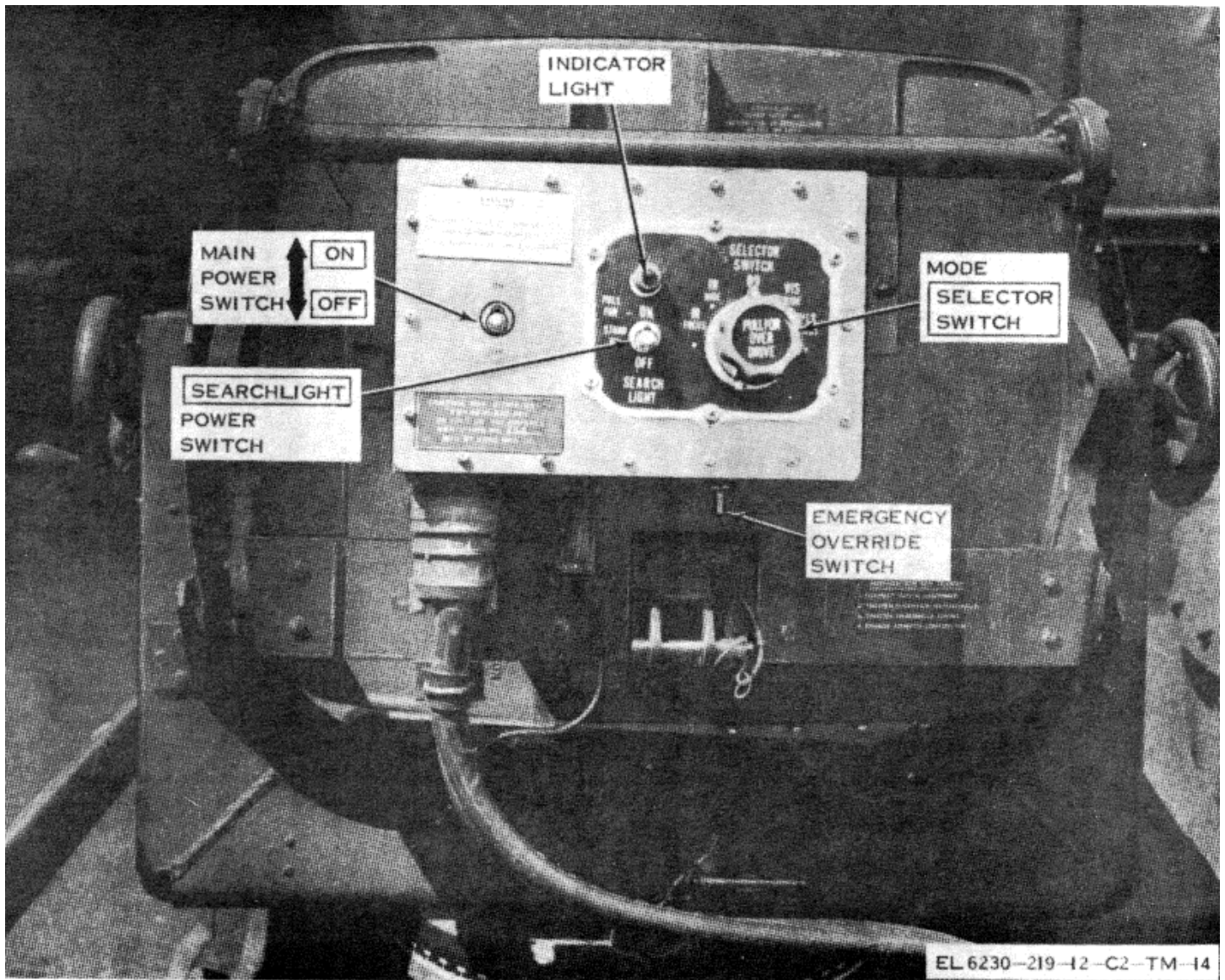

Figure 1-8. Control, Searchlight C-7164/GSS-14(V), front view.

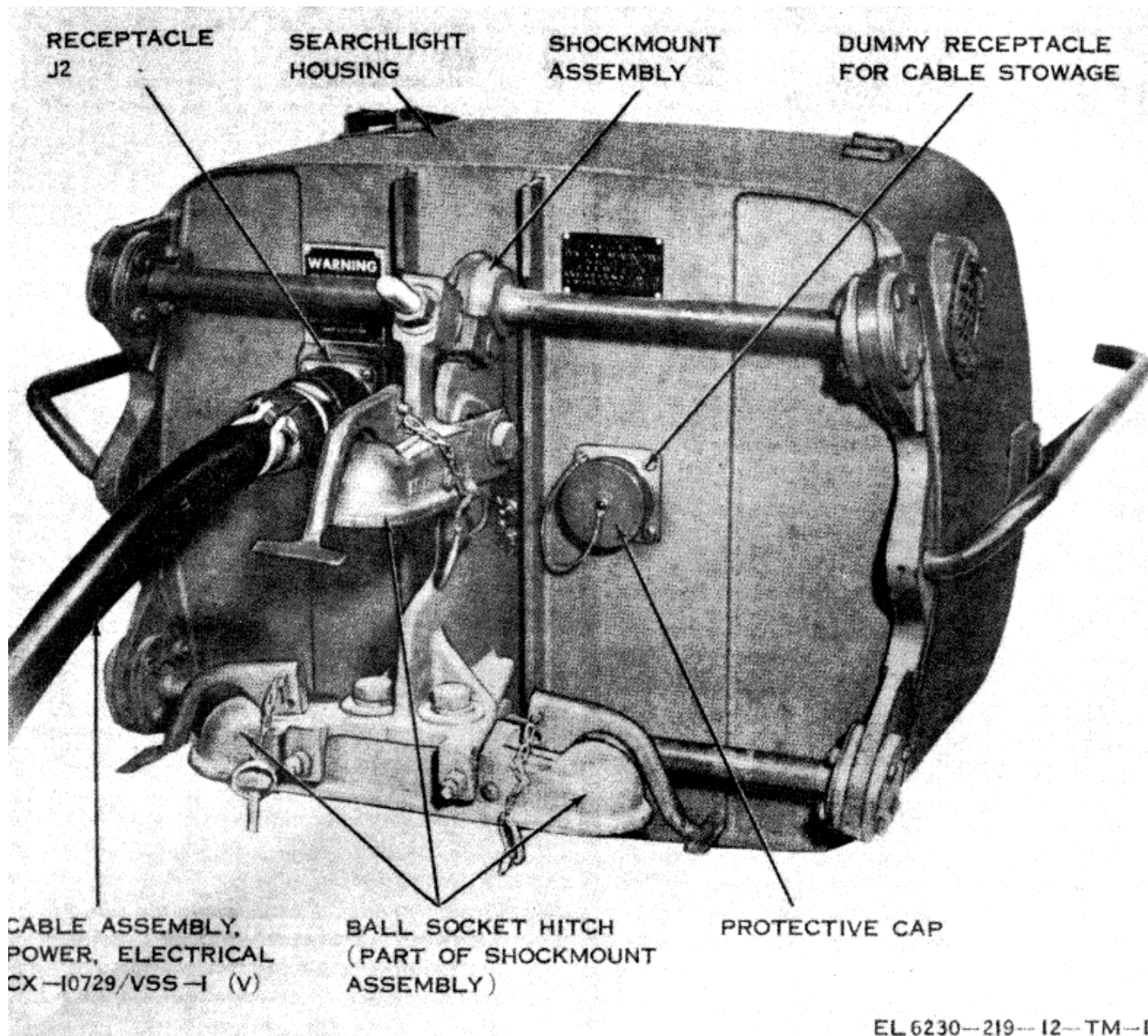

Figure 1-9. Searchlight subassembly (cowling assembly removed) and tank power cable.

e. *Differences in Searchlights.* All models are similar, except for the differences listed below.

(1) Relay panel assembly 9913 consists of a cover (mounting) plate and panel assembly to which circuit components and the individually replaceable control relays and time-delay circuits are mounted.

(2) Relay panel assembly model SC-D-613960 consists of a cover (mounting plate, diode CR2, circuit breaker CB1, and the relay assembly (metal can). The relay assembly contains the control relays and time-delay circuits that were individually replaceable in relay panel assembly 9913.

(3) On some searchlights the adjustable assembly, to which the primary reflector is mounted, is locked in a fixed position. The clear lens located directly in front of the xenon lamp has been removed. The secondary reflector located directly behind the xenon lamp has been removed.

1-13. Differences in Models

a. Searchlight AN/VSS-1(V) is tank mounted and uses Control Searchlight C-7163/VSS-1(V) (fig. 1-1).

b. Searchlight, Infrared AN/GSS-14(V) is jeep or tower mounted and used Control Searchlight C-7164/GSS-14(V) which contains the mode SELECTOR SWITCH, the SEARCHLIGHT power switch, main power switch, and the override switch. It is mounted directly to the rear of the searchlight subassembly and connected to receptacle J2 (fig. 1-8).

NOTE

Some AN/GSS-14(V) use MT-3900A/GSS-14(V) which affects the operating procedures for the searchlight. The operator positions the searchlight beam by manually operating the azimuth and elevation handwheels on the yoke. The azimuth and elevation scales can be illuminated by the scale illumination switches on the pedestal. The cable harness is routed to the control box through the mount allowing the input power cable to be connected to the pedestal.

Section III. BASIC PRINCIPLES

1-14. General

Operation of the searchlight consists of performing two basic functions: the prime function is the ignition and continual illumination of the xenon lamp, and the other function is control of the searchlight modes of operation.

a. *Ignition and Continual Illumination of Xenon Lamp.* This action is accomplished within the initial three seconds following the application of power to the igniter circuits (converter and igniter assemblies and the xenon lamp). The xenon lamp must go through three sequences to become fully lighted: the initial ionization and start of lamp conductance (arcing), increasing the level of lamp conductance, and maintaining lamp conductance for continual illumination. Three voltages are applied to the xenon lamp to produce the three sequences: 40-kilovolt (kv) radio frequency (rf) pulses, 55 volts dc, and 28 volts dc from the power source. The 40-kv rf pulses cause the initial ionization of the xenon gas and start of lamp conductance. The 55 volts dc increases the temperature of the xenon gas and increases the level of conduction so that 28 volts dc from the power source can maintain lamp conductance for continual illumination. After 3 seconds, the components and assemblies used for the initial ignition of the xenon lamp are shut off. The sequences will automatically be repeated if the xenon lamp is not lighted within the initial 3 seconds.

b. *Searchlight Modes of Operation.* The searchlight modes of operation are determined by the mode SELECTOR SWITCH and the SEARCHLIGHT power switch on the control boxes (fig. 1-7 and 1-8). The 1-12 mode SELECTOR SWITCH provides visible-focus, visible-wide, infrared-focus, infrared-wide, blackout, and overdrive

operating modes, and the SEARCHLIGHT power switch provides the standby mode. When the SEARCHLIGHT power switch is set from STANDBY to ON, power is applied to the ignition circuits, causing the xenon lamp to become lighted. When lighted, the xenon lamp produces visible light. The light originating from the xenon lamp is directed into the primary reflector and projected by the searchlight as a visible-focus beam (A, fig. 1-10). Wide-beam operation, in either visible or infrared light, is obtained when the refractor lens is placed in the path of the light beam (B and D, fig. 1-10). Infrared light, in either the focus or wide-beam operating modes, is obtained when the infrared filter is placed in the path of the light beam (C and D, fig. 1-10). The metal blackout shield is placed in the path of the light beam when in the blackout or standby modes, preventing emission of light (E, fig. 1-10). The override mode produces a light of higher intensity in either the visible or infrared operating modes, by causing an increase in current through the xenon lamp.

1-15. Equipment Functioning

a. *General.* When the main power switch in the tank or on the control box (fig. 1-8) is set to ON, 28 volts dc is distributed throughout the searchlight subassemblies and the control box, which readies the searchlight for operation. When the SEARCHLIGHT power switch is set to STANDBY, 28 volts dc is applied to specific components within the searchlight subassemblies, the blower motor is turned on to cool the xenon lamp, the relay

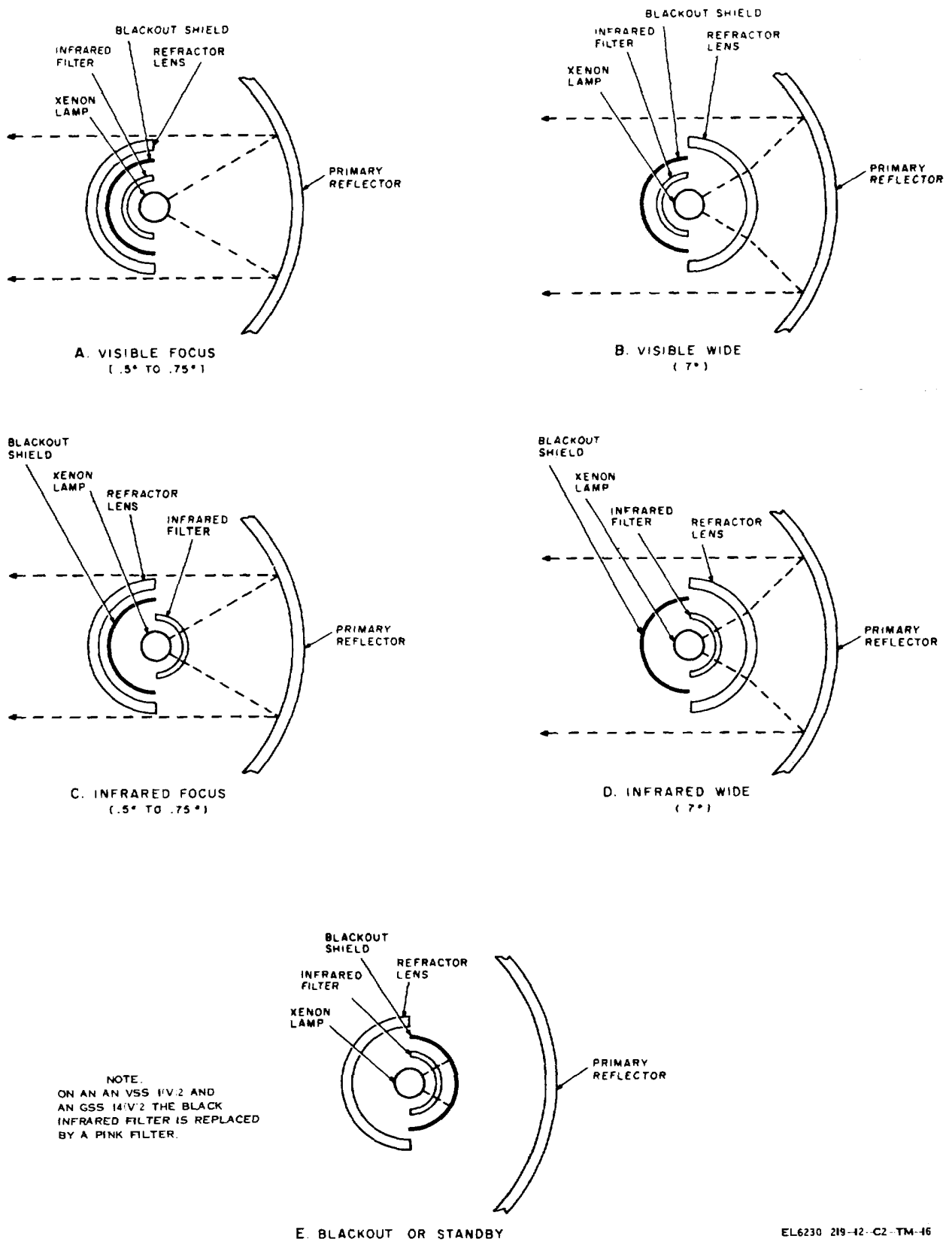

EL6230 219-42-C2-TM-16

Figure 1-10. Searchlight modes of operation.

assembly is energized, and the ignition circuits (converter, igniter, and xenon lamp) become operational, which causes the xenon lamp to light. Although the xenon lamp is lighted, emission of light does not occur; the metal blackout shield is in the path of the light beam (E, fig. 1-10). When the SEARCHLIGHT power switch (fig. 1-8) is set to ON, the metal blackout shield is moved away from the path of the light beam and allows emission of light to occur.

b. Blower Motor. When the SEARCHLIGHT power switch is set to STANDBY or ON, 28 volts dc is applied to the blower motor and causes it to operate and cool the xenon lamp. Another circuit has been provided to insure cooling of the xenon lamp after the searchlight has been shut off. When the searchlight has been turned on for approximately three to four minutes, the normal temperature within the blower system will exceed 140° F (60° C). This action causes thermoswitch S7 to close, applying 28 volts dc to the blower motor; therefore, when the SEARCHLIGHT power switch is set to OFF, the blower motor will continue to operate. When the temperature within the blower system falls below 130° F (54.4° C), thermoswitch S7 will open, and the blower motor will cease to operate. This additional cooling of the xenon lamp is required to prevent heat damage, and is the reason why instructions specify use of the SEARCHLIGHT power switch and not the main power switch to shut off the searchlight. The main power switch is to be set to OFF only after the blower motor

has stopped or in an emergency situation.

c. Relay Panel Assembly. The relay panel assembly contains the relays and circuitry necessary to perform three functions: control of the searchlight modes of operation, automatic shutoff of the igniter assembly and the converter assembly when the xenon lamp is fully lighted, and automatic limiting of the overdrive circuit to 17.5 seconds \pm 2.5. The searchlight modes of operation are determined by the control voltages (28 volts dc) which the relay panel assembly receives from control boxes. The relay panel assembly causes the proper drive motors to become energized; the drive motors, in turn, place the metal blackout shield, the refractor, and the infrared filter lens in their proper positions.

d. Ignition Circuits. When the SEARCHLIGHT power switch is set to STANDBY or ON, 28 volts dc is applied to the converter and igniter assemblies. The converter assembly transforms the 28-volt dc input to a 330-Hertz (Hz), ac output plus a dc output, and supplies these voltages to the igniter assembly. The igniter assembly steps up the ac voltage to 40 kv at a frequency from 2 to 8 megahertz (MHz) and applies this rf voltage, in series with the dc voltage, to the xenon lamp. The rf voltage causes the xenon gas to ionize and start lamp conduction. The 55-volt dc signal increases the temperature of the xenon gas which increases the level of lamp conduction and, thereby, maintains lamp illumination. When illumination has been achieved, the converter assembly shuts down, and lamp illumination is sustained from the 28-volt dc source.

CHAPTER 2 INSTALLATION

Section I. SERVICE UPON RECEIPT OF EQUIPMENT

2-1. Unpacking

a. *AN/VSS-1(V)* (fig. 2-1 and 2-2). When packed for shipment, the searchlight is placed in a single packing box. Use a forklift truck, or suitable hoist, and move the packing box as close to the point of installation as possible. Unpack the searchlight as follows:

CAUTION

Be careful when unpacking the searchlight to prevent it from being damaged.

- (1) Cut the metal straps.
- (2) Remove the lag bolts that secure the top cover of the packing box and remove the top cover.
- (3) Remove the fastening devices which secure the searchlight to the base of the packing box and remove the searchlight.

b. *AN/GSS-14(V)* (fig. 2-3 and 2-4). The searchlight is shipped in a single packing box which is 32 inches wide, 28 inches deep, and 39 inches high, and weighs 490 pounds. Use a forklift truck or suitable hoist to move the packing box close to the point of the installation.

NOTE

Searchlights using the MT-3900/GSS-14(V) or MT-3900A/GSS14(V) are packed, shipped, unpacked, and installed in a similar manner. To

avoid duplication only the MT-3900A/GSS-14(V) mount will be discussed. Refer to TM 11-2300-351-15-3 for more detailed instruction concerning the MT-3900/GSS-14(V).

- (1) Cut the metal straps (not shown).
- (2) Remove the lag bolts (not shown) that secure the top cover of the packing box to the base.

CAUTION

Be careful when uncrating the searchlight to avoid damaging the equipment.

- (3) Remove the top cover of the packing box.
- (4) Remove the five bolts that secure the searchlight to the base of the packing box.
- (5) Use a forklift truck, crane, or equivalent to remove the searchlight.

2-2. Checking Unpacked Equipment

a. Inspect the equipment for damage incurred during shipment. If the equipment has been damaged, report the damage on DD Form 6 (para 1-3).

b. Check to see that the equipment is complete as listed on the packing slip. If a packing slip is not available, check the equipment against items comprising an operable equipment (para 1-8). Report all discrepancies in accordance with procedures given in TM 38-750.

Section II. INSTALLATION INSTRUCTIONS

2-3. General

CAUTION

When handling the searchlight take care not to damage the blower motor screens (fig. 3-2), rest or support the searchlight on a level surface.

Installation of the searchlight is performed by vehicular maintenance personnel. Refer to DA Pam 310-4 for the

technical manual which describes searchlight installation procedures applicable to the appropriate carrier or application.

2-4. Servicing

a. Perform the operator's weekly preventive maintenance checks and services (para 4-6).

b. When checks and services are completed, report the equipment ready for operation.

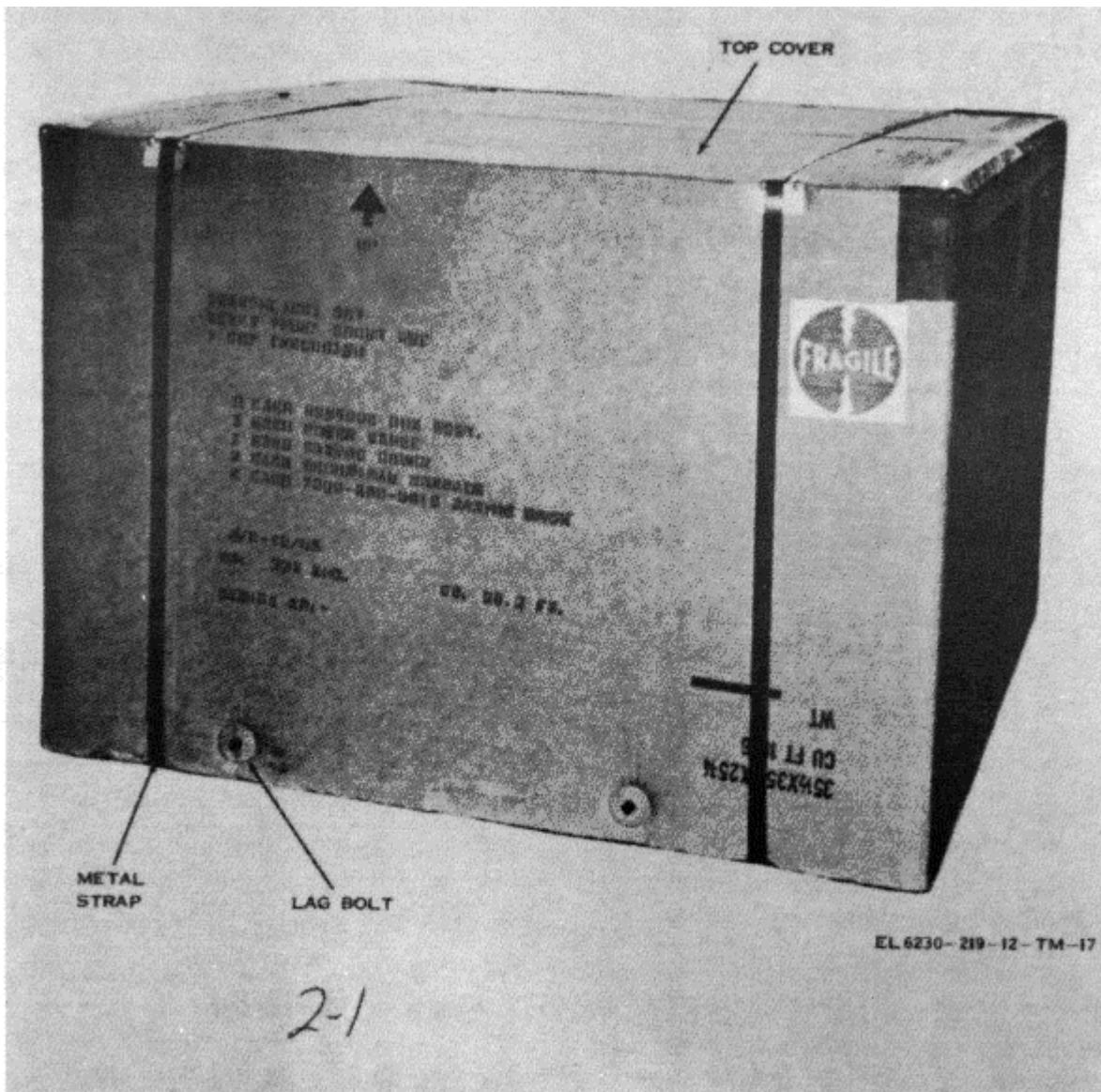

Figure 2-1. Typical packing of the AN/VSS1(V)

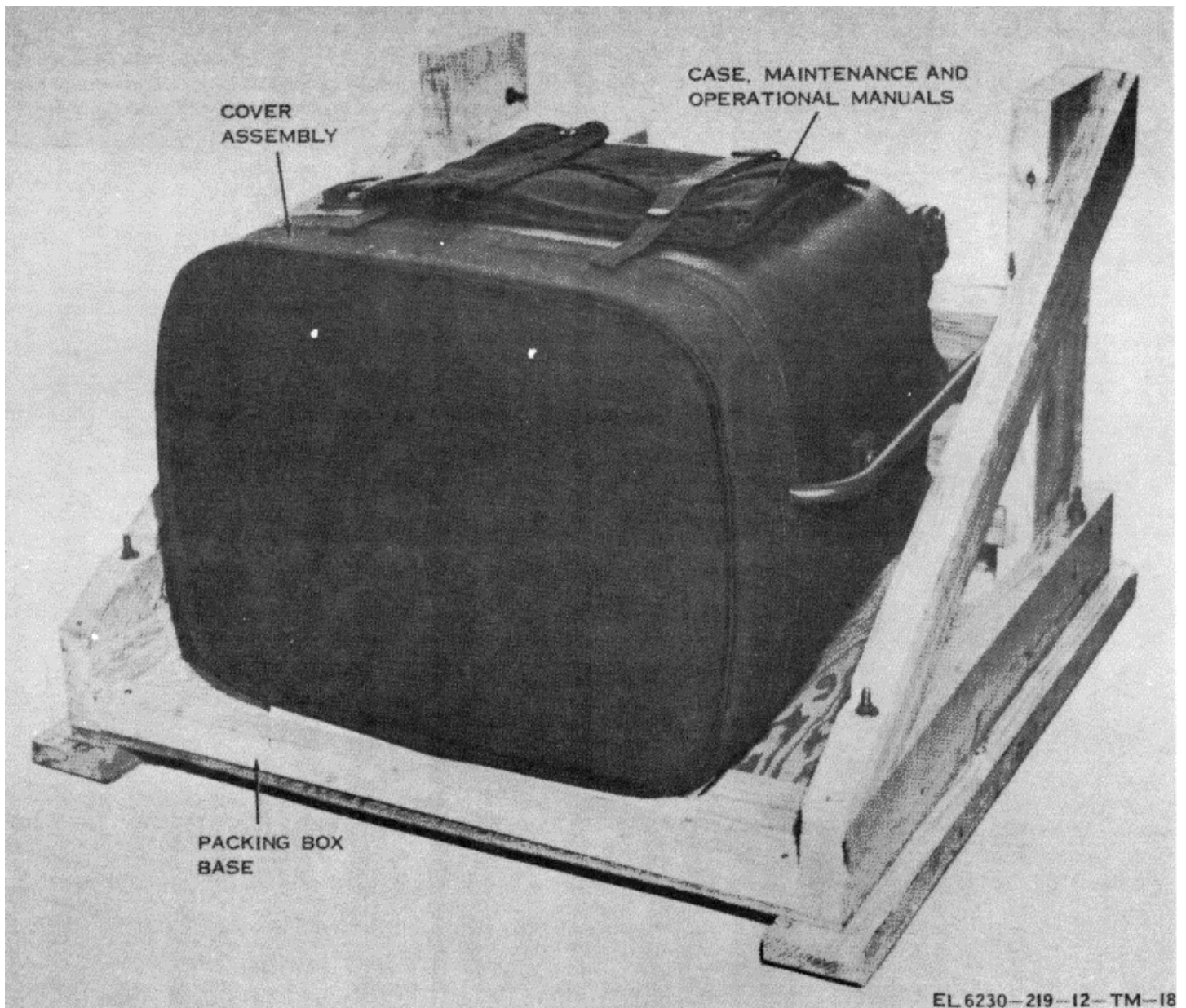

Figure 2-2. Typical packing of the AN/VSS-1(V), top cover removed.

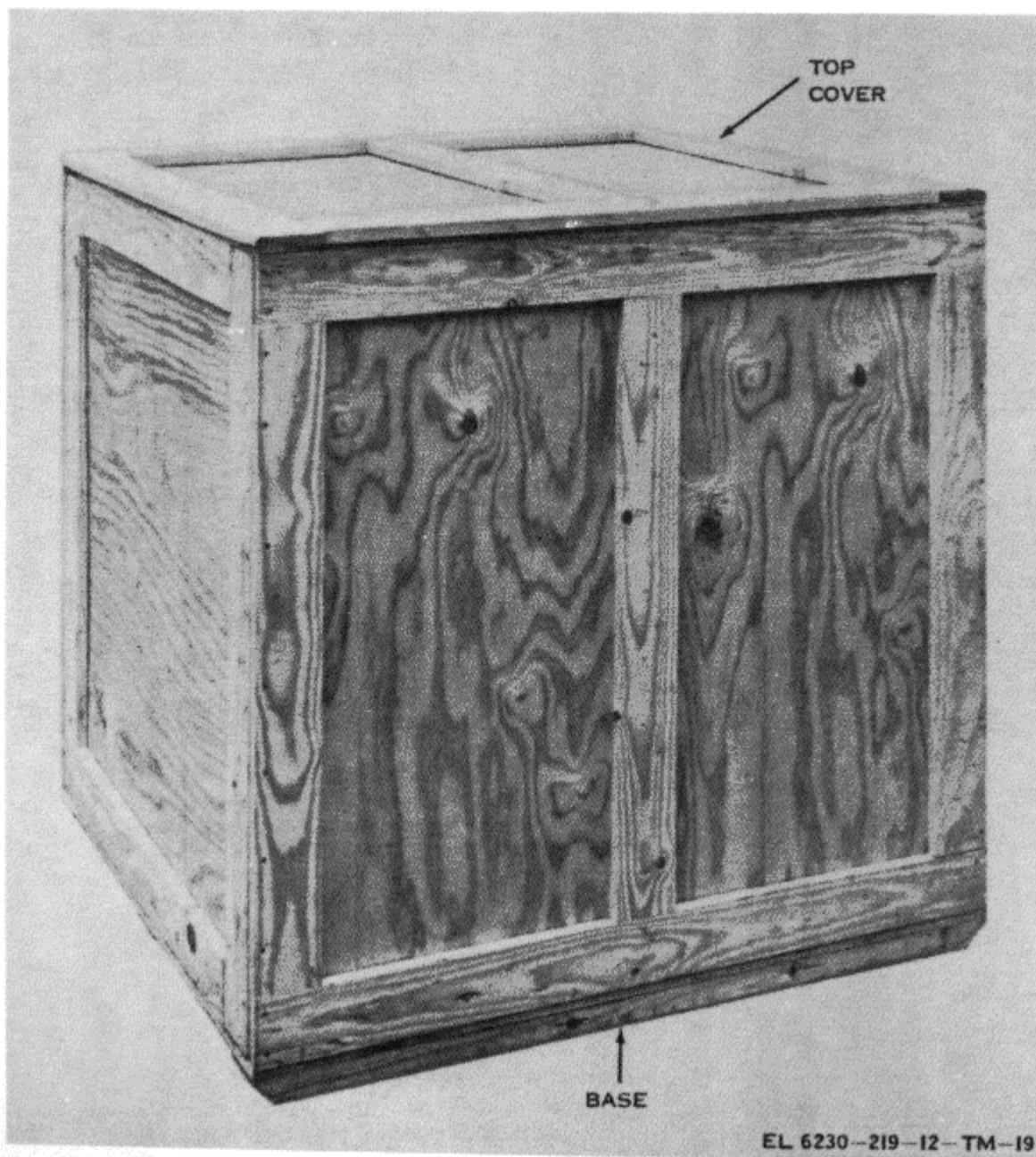

Figure 2-3. Typical packing of the AN/GSS-14(V).

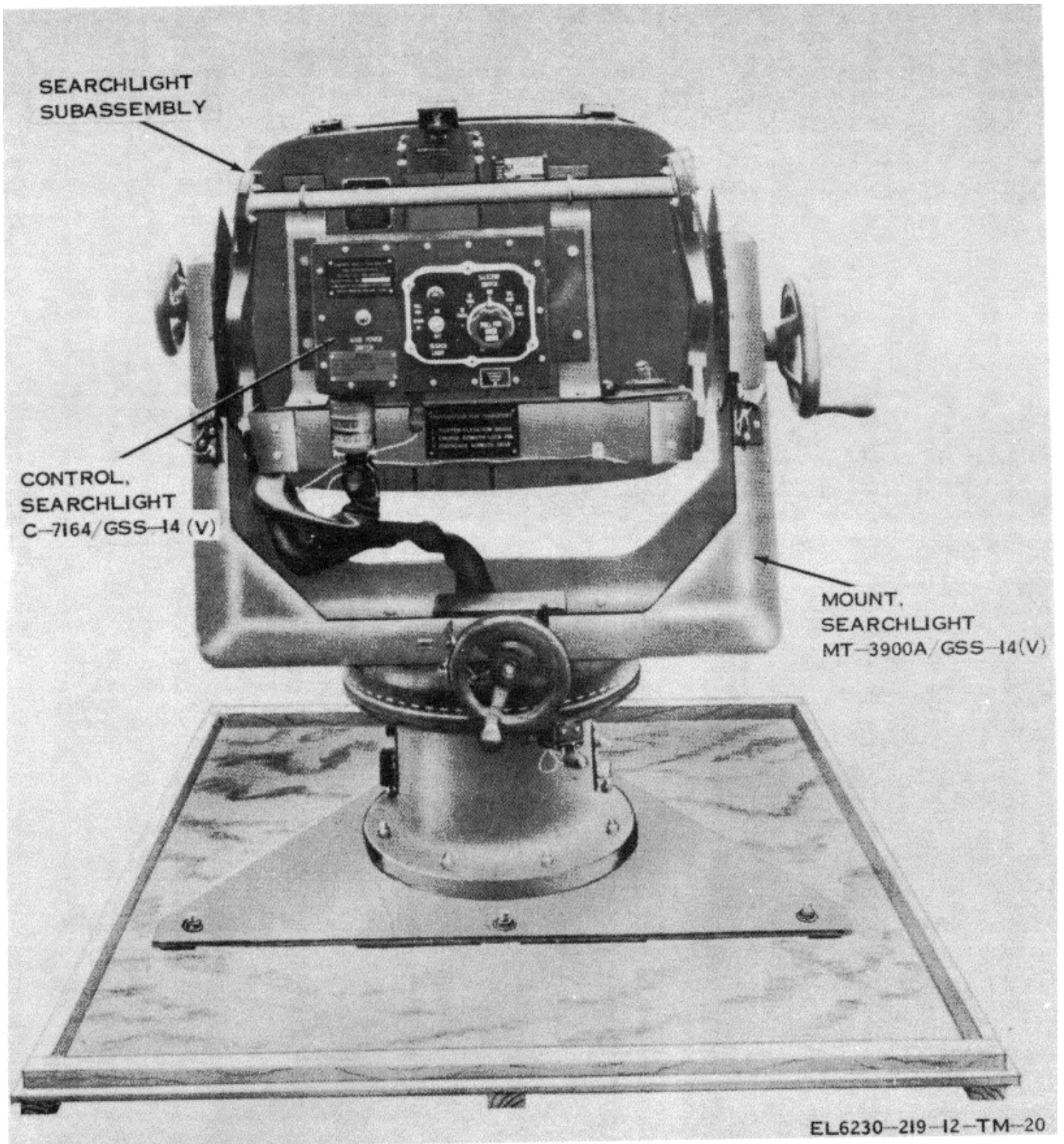

Figure 2-4. Typical packing of the AN/GSS-14(V), top cover removed.

**CHAPTER 3
OPERATING INSTRUCTIONS**

Section I. CONTROLS AND INDICATORS

3-1. General

This section describes the switches and the indicator light common to Control, Searchlight C-7163/VSS-1(V) and Control, Searchlight C-7164/GSS-14(V). It also covers the controls and indicators on the MT-3900A/GSS-14(V). On the AN/GSS14(V) the main power switch and the emergency override switch are located on the control box. On the AN/VSS-1(V), the main power switch (not shown) is located within the tank, but is not part of the searchlight.

3-2. Operator's Controls and Indicators

a. Control Box (fig. 1-7 and 1-8).

Control or indicator	Function
SEARCHLIGHT power switch	<p><i>Pos</i> STANDBY <i>Function</i> Xenon lamp is illuminated but light is not emitted from searchlight.</p> <p>ON Light is emitted from search light.</p>
Mode SELECTOR SWITCH	<p>IR FOCUS Searchlight emits narrow beam of infrared light.</p> <p>IR WIDE Searchlight emits wide beam of infrared light.</p> <p>BO Searchlight is placed in blackout condition; xenon lamp is illuminated but light is not emitted from searchlight.</p> <p>VIS WIDE Searchlight emits wide beam of visible light.</p> <p>VIS FOCUS Searchlight emits narrow beam of visible light.</p>
	<p>OVER-DRIVE Intensity of either visible or infrared light is increased by approximately 50 percent for 17.5 seconds ± 2.5. (Red indicator light glows.)</p>
	<p>Indicator light Indicator light glows when searchlight is placed in overdrive mode of operation, or when high-temperature</p>

Control or Indicator	Function
MAIN POWER SWITCH (Control, Searchlight C-7164/GSS-14(V))	<p><i>Pos</i> alarm system is actuated by higher-than-normal temperature within xenon lamp cooling system.</p> <p>WARNING</p> <p>Continued operation of searchlight when high temperature is indicated will result in xenon lamp explosion, causing damage to searchlight and possible serious injury to personnel.</p> <p>In the ON position, power is applied to searchlight.</p> <p>WARNING</p> <p>To prevent xenon lamp explosion and possible injury to personnel and equipment, set the main power switch to OFF only after blower motor within searchlight subassembly has stopped.</p> <p>In on position (against spring action), xenon lamp can be illuminated even though vehicle engine is not operating.</p> <p>In OFF position, xenon lamp can be illuminated only if the vehicle engine is operating properly.</p> <p>CAUTION</p> <p>Do not operate searchlight with the emergency override switch set to on unless it is absolutely necessary. Damage to the vehicle battery system may occur.</p>
Emergency override switch (Control, Searchlight C-7164/GSS-14(V))	<p>In on position (against spring action), xenon lamp can be illuminated even though vehicle engine is not operating.</p> <p>In OFF position, xenon lamp can be illuminated only if the vehicle engine is operating properly.</p> <p>CAUTION</p> <p>Do not operate searchlight with the emergency override switch set to on unless it is absolutely necessary. Damage to the vehicle battery system may occur.</p>

b. MT-3900A/GSS-14(V) (fig. 3-1).

NOTE

Refer to TM 11-2300-351-15-3 for information concerning the MT-3900/GSS-14(V).

Control or indicator	Function
Azimuth handwheel	Adjusts searchlight in azimuth when azimuth engagement lever is engaged.
Elevation handwheel	Adjusts searchlight elevation.
Elevation brake handwheel	Locks searchlight in elevation.
Elevation scale setscrew	Prevents elevation scale from sliding once it has been set.
Azimuth set latch	Prevents azimuth scale from sliding once it has been set.
Scale illumination switch	Controls lamps used to illuminate scales and level.
Fuse	Provides overcurrent protection for

Control or indicator	Function	Control or indicator	Function
Levels Level adjust screws Azimuth scale	lamps used to illuminate scales and level. Indicate when searchlight is level. Used to properly orient level. A sliding scale used for proper orientation of searchlight and to indicate azimuth of searchlight. Indicates in mils from 0 to 6,400.	Azimuth engagement lever	Engages or disengages azimuth handwheel. Horizontal position engages azimuth drive which allows azimuth handwheel to mechanically rotate searchlight in azimuth. Vertical position disengages azimuth drive and azimuth handwheel which allows searchlight to be manually rotated in azimuth.
Elevation scale	A sliding scale used for proper orientation of searchlight and to indicate elevation of searchlight. Indicates in mils from -700 to + 1,400.		

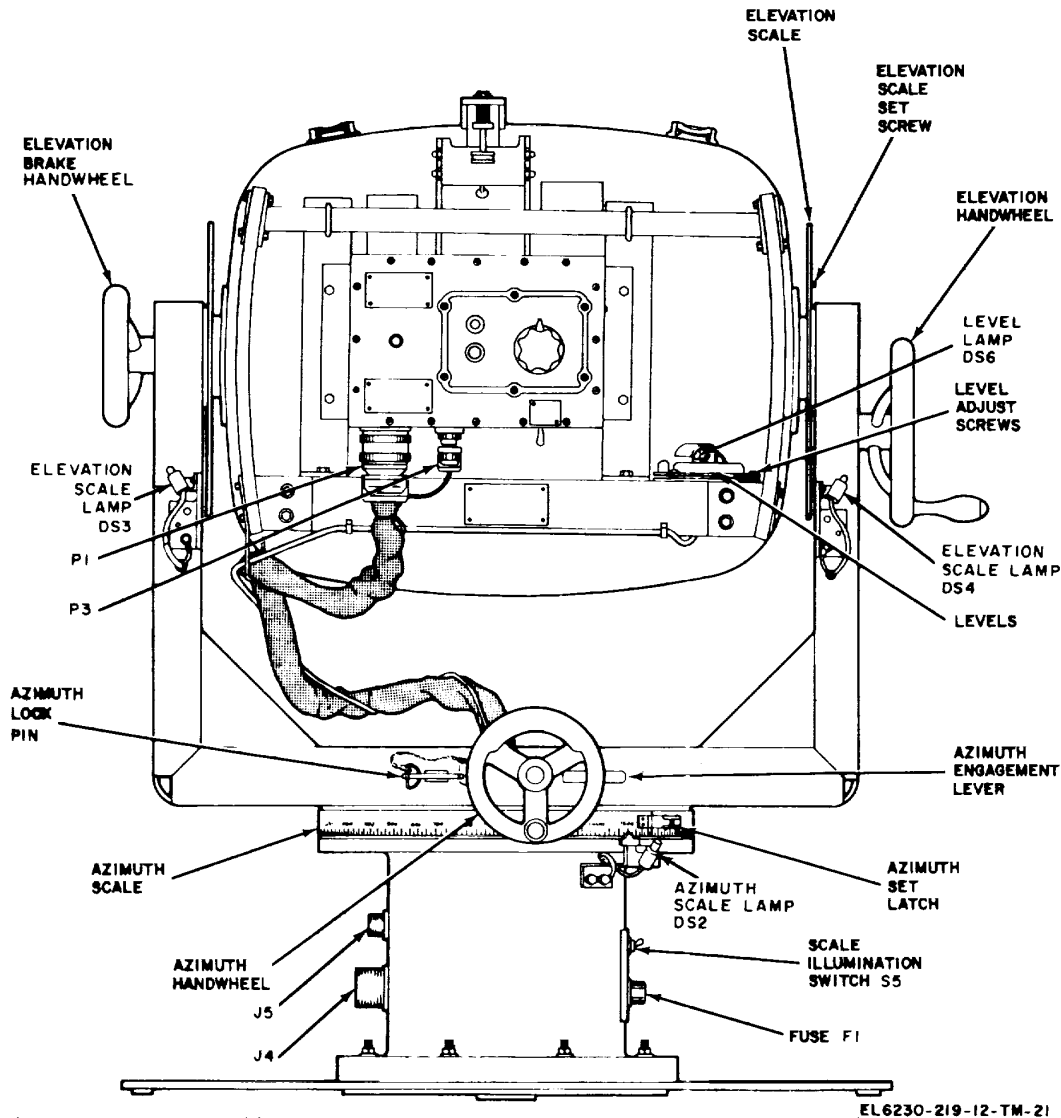

Figure 3-1. Operator's controls and indicators (MT-3900A/GSS- 14(V)).

3-3. Blower Inlet and Outlet Ports

(fig. 3-2)

The blower motor within the searchlight circulates cool

air by the xenon lamp to prevent xenon lamp explosion. The blower inlet and outlet screens must be free of obstruction for the blower system to operate properly.

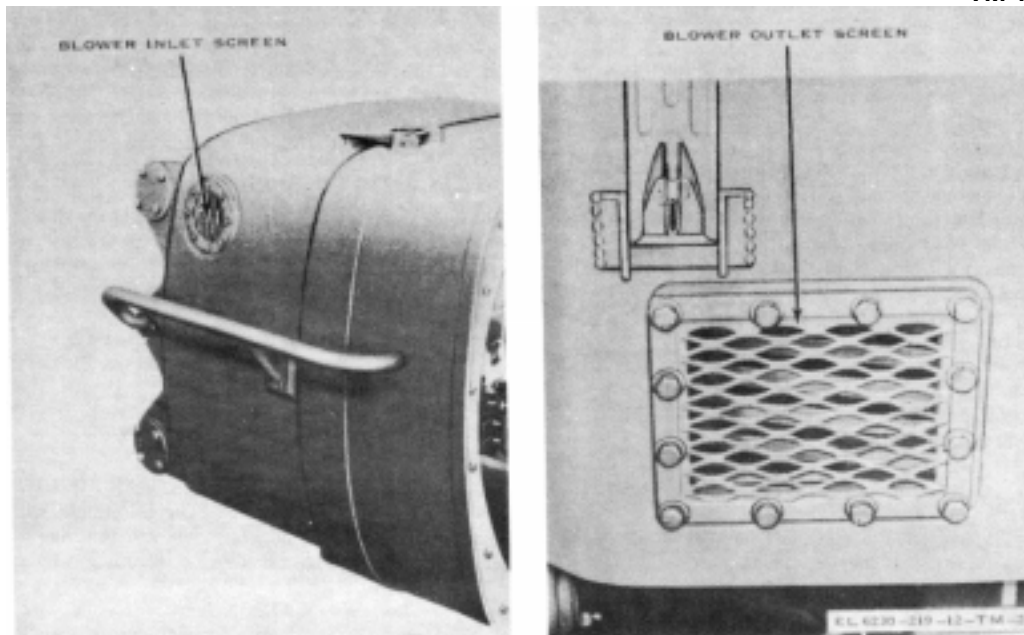

Figure 3-2. Location of blower inlet and outlet screens.

Section II. OPERATION UNDER USUAL CONDITIONS

3-4. Starting Procedures

a. *Control Box* (fig. 1-7 and 1-8). Before starting the power source that supplies power to the searchlight, be sure the SEARCHLIGHT power switch and the main power switch are set to OFF.

(1) Be sure that the blower inlet and outlet screens are free of obstructions (fig. 3-2).

(2) Start the power source that supplies power to the searchlight. Refer to the applicable manual for proper instructions.

(3) Set the main power switch to ON.

(4) Set the mode SELECTOR SWITCH to the desired mode of operation. To turn the mode SELECTOR SWITCH beyond BO (to VIS WIDE or VIS FOCUS), press the plunger on the mode SELECTOR SWITCH control knob.

WARNING

Do not operate the searchlight if the blower motor does not operate; the xenon lamp may explode.

(5) Pull out and upward on the SEARCHLIGHT power switch and place it at STAND BY. This action causes the blower motor to operate and the xenon lamp to illuminate; light will not emit from the searchlight.

WARNING

Do not look directly into the searchlight beam. Blindness or

serious eye damage may result.

Do not operate the searchlight in the beam visible modes while personnel are within 200 meters of the beam path.

Personnel may suffer temporary flash blindness at ranges in excess of 200 meters when the searchlight is operated in either of the visible modes.

(6) Pull out and upward on the SEARCHLIGHT power switch and place it at ON. This action will cause light to emit from the searchlight.

(7) To change the searchlight mode of operation, set the mode SELECTOR SWITCH to the desired position.

CAUTION

Unless directed by the commanding officer, the overdrive mode is to be used only against the enemy or during preventive maintenance or repair. Do not manually operate the searchlight in the overdrive mode of operation beyond the normal timing sequence.

Place the SEARCHLIGHT power switch to OFF if a malfunction occurs

which causes the searchlight to remain in the overdrive mode of operation beyond the normal timing sequence. Do not operate the searchlight in overdrive more than once in any 5-minute period of operation.

(8) To place the searchlight in the overdrive mode of operation, pull the mode SELECTOR SWITCH control knob outward and release it immediately. The indicator lamp on control boxes will illuminate and the intensity of the light beam will increase. After 17.5 seconds \pm 2.5 have elapsed, the overdrive mode will automatically cut off; this action causes the indicator lamp to go off and the intensity of the light beam to return to normal.

b. MT-3900A/GSS-14 (V).

NOTE

Refer to TM 11-2300-351-15-3 for MT3900/GSS14(V) operating instructions.

(1) *Leveling alignment.*

(a) Remove the azimuth lockpin and release the elevation brake.

(b) Adjust the elevation handwheel until the levels indicate that the searchlight is level.

(c) If necessary, loosen the elevation setscrew and set the elevation scale so that the pointer is at the 000-mil mark on the elevation scale.

(d) Without moving the elevation scale, tighten the elevation setscrew.

(2) *Azimuth alignment.* The following procedure is required to orient the searchlight when it is used for fire control purposes. Direction for this operation will be received by field command.

(a) Determine the azimuth bearing of the searchlight from information received from field command.

(b) Release the azimuth set latch and position the azimuth scale until the azimuth pointer is at the mils setting representing the proper azimuth bearing.

(c) Without moving the azimuth scale, close the azimuth set latch.

(3) *Starting procedure.*

(a) Turn the elevation brake handwheel and release the elevation brake.

(b) Turn the elevation handwheel to position the searchlight in elevation.

(c) To mechanically position the

searchlight beam in azimuth, set the azimuth engagement lever to the horizontal (side) position to engage the azimuth handwheel.

(d) To manually position the searchlight beam in azimuth, set the azimuth engagement lever to the vertical (upward) position to disengage the azimuth handwheel; turn the yoke manually.

(e) Set the scale illumination switch to the on position to turn on the scale illumination lamps.

3-5. Standby Procedure

The searchlight can be placed in a standby condition which will prevent emission of light from the searchlight but will allow the xenon lamp to remain illuminated. This is accomplished by either of the following methods:

a. Place the mode SELECTOR SWITCH at BO.

b. Pull out and upward on the SEARCHLIGHT power switch and set it to STAND BY.

3-6. Normal Stopping Procedure

Shut off the searchlight as follows: a. Pull out and downward on the SEARCHLIGHT power switch and set it to OFF. The searchlight will shut off; however, the blower motor will continue to operate if the searchlight has been operating for 3 to 4 minutes or more.

WARNING

To prevent xenon lamp explosion and possible injury to personnel and equipment wait until the blower motor stops before continuing to the next procedure.

b. After the blower motor stops, set the main power switch to OFF.

c. Set the scale illumination switch to the off position.

d. Shut off the power source that supplies power to the searchlight. Refer to the applicable manual for proper instructions.

3-7. Emergency Stopping Procedure

WARNING

To prevent injury to personnel due to the possibility of a xenon lamp explosion, clear all personnel away from the front of the searchlight.

In an emergency, it may be necessary to turn off the searchlight in the shortest possible time. To do this, shut off the power source that supplies power to the searchlight.

Section III. OPERATION UNDER UNUSUAL CONDITIONS

3-8. Forging

CAUTION

Do not operate the searchlight when fording through deep water.

a. The tank searchlight can be forded through deep

water without damaging the searchlight internal components. The adjustable cowling latches are used to vary the tension on the cowling gasket which forms a waterproof seal between the cowling assembly and the searchlight housing assembly.

b. Be sure that the cowling gasket is in good condition and the cowling latches have been properly adjusted. A properly adjusted cowling latch requires from 8 to 12 pounds of pull at the extreme end of the cowling latch lever to release it from the closed position. Notify higher category of maintenance if the cowling latches require adjustment.

c. Water will flow into the heat exchanger assembly, through the open intake and exhaust ports, without damaging the searchlight.

d. The mounted searchlights are not designed to be forded through deep waters. Damage to the mount will occur.

3-9. Operation in Arctic Climates

Subzero temperatures and conditions associated with cold weather affect the efficient use of the searchlight. Instructions for operation of the searchlight under these adverse conditions are as follows:

a. Before operating the searchlight, inspect the exterior surfaces and remove any accumulations of ice or snow, especially around the cowling glass and blower inlet and outlet screens.

b. During long periods of operation, inspect the blower inlet and outlet screens and remove any accumulations of ice or snow.

c. Cover the searchlight when it is not in operation.

3-10. Operation In Tropical Climates

In the tropics, moisture and humidity can cause severe problems to the searchlight. Condensation of moisture on the equipment occurs frequently; therefore, minimize

the possibility of damage by moisture by taking precautions as follows:

a. Keep the searchlight, cables, and connectors clean and dry.

b. Properly tighten all electrical connectors.

c. Be sure that the cowling gasket is in good condition and the cowling latches have been properly adjusted (para 3-8). This action will prevent moisture from entering the searchlight subassembly.

d. Inspect the blower inlet and outlet screens and remove any obstructions.

e. Cover the searchlight when it is not in operation.

3-11. Operation In Desert Climates

Heat, dust, and sand are primary problems in desert areas; therefore, prevent the possibility of damage by taking precautions as follows:

a. Keep the equipment clean.

b. Be sure that the cowling gasket is in good condition. Make sure that the cowling latches have been properly adjusted (para 3-8) to prevent dust and sand from entering the searchlight subassemblies.

c. Perform a daily inspection of the heat exchanger assembly blower intake and exhaust ports for an accumulation of dirt, dust, and sand. Accumulated dirt can be flushed from the heat exchanger assembly by pouring water into the blower intake port. The heat exchanger assembly is sealed and will prevent water from entering the searchlight subassemblies.

**CHAPTER 4
OPERATOR AND ORGANIZATIONAL MAINTENANCE INSTRUCTIONS**

Section I. PREVENTIVE MAINTENANCE

4-1. General

Preventive maintenance is the systematic care, servicing, and inspection of equipment to prevent the occurrence of trouble, reduce downtime, and assure that the equipment is serviceable. If inspection of the equipment reveals any damage which cannot be remedied by operator or organizational maintenance personnel, a higher category of maintenance or repair is required. Records and reports of these checks and services must be made in accordance with the requirements set forth in TM 38-750.

4-2. Operator's Weekly Preventive Maintenance

Table 4-1 in paragraph 4-6 lists the preventive maintenance checks and services to be performed by the operator. The checks and services are to be performed in sequence.

4-3. Organizational Monthly Preventive Maintenance

Table 4-2 in paragraph 4-12 lists the preventive maintenance checks and services to be performed by organizational maintenance personnel. The checks and services are to be performed in sequence.

Section II. OPERATOR'S PREVENTIVE MAINTENANCE

4-4. Scope of Operator's Maintenance

a. The maintenance duties assigned to the operator of the searchlight are required weekly. Paragraph 4-6 specifies checks and services that must be accomplished once each week, or under special conditions listed below.

(1) When the searchlight is initially installed.

(2) When the searchlight is reinstalled after removal for any reason.

(3) Before going on a mission, and as soon after completion of the mission as possible.

b. The duties assigned do not require special tools or test equipment.

4-5. Materials Required for Operator's Maintenance

- a. Lint-free cloth (NSN 8305-00-170-5062).
- b. Fresh water and mild soap.
- c. Denatured alcohol (NSN 6810-00-201-0906).
- d. Lens tissue (NSN 5640-00-393-2090).

4-6. Operator's Weekly Preventive Maintenance Checks and Services

Refer to table 4-1 for operator's weekly preventive maintenance checks and services.

Table 4-1. Operator's Preventive Maintenance Checks and Services

Total task/hours required. 0 8

Sequence	ITEM TO BE INSPECTED PROCEDURE	Work units (T/H)
1	Inspect the following: a. Cover assembly for tears, damaged buckles, dirt, and proper fit with cowling assembly; clean if needed. Refer to figure 1-3 for parts location.	0.3

Sequence number	ITEM TO BE INSPECTED PROCEDURE	Work units (T/H)
	<ul style="list-style-type: none"> b. Searchlight housing assembly for obstructions in the blower inlet and outlet screens. Clean exterior surface, including nameplates; be sure that nameplates are legible. Inspect latches; check to see that they close properly. Refer to paragraphs 3-3 and 3-8b for detailed instructions. c. Receptacles and cables for corrosion, stripped threads, bent or broken pins, damaged insulation, broken strands, and proper fit to receptacles. d. Primary reflector for scratches or pitted surface. Clean with pure alcohol; use lens tissue or clean, lint-free cloth. e. Indicator light for dirt; clean if needed. f. Lamp housing assembly for cracked or broken lens and corrosion. Refer to figure 1-5 for parts location. g. Cowling assembly for cleanliness. Remove and clean glass if needed. Replace cowling assembly and check for proper fit with searchlight housing assembly. Inspect latches; check to see that they close properly. h. Levels for cracked glass; clean (fig. 3-1), if necessary. 	

Sequence number	ITEM TO BE INSPECTED PROCEDURE	Work units (T/H)
2	<p><i>l.</i> Mounts for dirt; clean if necessary.</p> <p>SEARCHLIGHT</p> <p>Perform an operational check by following start, standby, and stop procedures. Place searchlight in all modes (including OVERDRIVE) of operation; check for proper response. If indicator lamp on CONTROL BOX is defective, remove lens cap; turn it counterclockwise and replace lamp. Replace lens cap. Refer to paragraph 3-4 through 3-6 for operation, standby, and stop procedures.</p>	0.4
3	<p>MT-3900A/GSS-14(V)</p> <p>Check scale illumination switch for proper operation with no binding. Refer to figure 3-1 for switch location. Set scale illumination switch to on. If azimuth and elevation lamps are not on, replace fuse. Refer to figure 3-1 for parts location. Set scale illumination switch to on. If lamps are defective, remove lens cap; replace lamp. Inspect for dirt; clean if necessary. Refer to figure 3-1 for parts location.</p>	0.1

NOTE

Refer to TM 11-2300-351-15-3 for operator's preventive maintenance procedures for MT-3900/GSS-14(V).

4-7. Cleaning

Inspect the exterior of the searchlight subassembly, control box, and mount. The exterior surfaces should be clean and free from dirt and grease.

WARNING

Make sure that the searchlight is turned off and cool before cleaning.

a. Wash the exterior of the searchlight subassembly with a low-pressure hose or by using buckets of fresh water. Dry equipment surfaces with a clean, lint-free cloth.

b. If dirt is difficult to remove, use a damp cloth and mild soap; flush with fresh water. Dry equipment surfaces with a clean, lint-free cloth.

c. When the exterior surface contains only dust or loose dirt, wipe it with a clean, lint-free cloth.

d. Clean the front glass of the cowling assembly; use a clean, lint-free cloth. If the dirt is difficult to remove, dampen the cloth with water; if necessary, use a mild soap.

4-8. Operator's Troubleshooting

Troubleshooting the searchlight by the operator is based on the operational checks in the operator's weekly preventive maintenance checks and services table (para 4-6). To troubleshoot the searchlight, perform the operational checks; report all abnormal symptoms to higher category of maintenance personnel.

4-9. Conversion for Travel

a. Tank-Mounted Searchlights. Cover the searchlight with the cover assembly.

b. Mounted Searchlight. The following procedures apply only on vehicle-mounted searchlights.

(1) Approximately level and direct the light so that it will be pointed toward the rear of the vehicle.

(2) Turn the elevation brake handwheel to apply the elevation brake.

CAUTION

Do not use excessive pressure in tightening the brake. Excessive pressure is unnecessary and may damage the brake.

(3) Turn the azimuth handwheel to align the hole located on the place below the yoke and the corresponding hole on the pedestal and insert the azimuth lockpin.

(4) Set the azimuth engagement lever to the vertical (up) position to disengage the azimuth drive system.

(5) Cover the searchlight with the cover assembly.

NOTE

Refer to TM 11-2300-351-15-3 for conversion for travel procedures covering mounted searchlights that use the MT-3900/GSS-14(V).

Section III. ORGANIZATIONAL PREVENTIVE MAINTENANCE

4-10. Scope of Organizational Maintenance

a. The maintenance duties assigned to organizational maintenance personnel are required monthly. Paragraph 4-12 specifies checks and services that must be accomplished once each month.

b. The duties assigned do not require special tools or test equipment.

4-11. Materials Required for Organizational Maintenance

- a.* Lint-free cloth (NSN 8305-00-170-5062).
- b.* Fresh water and mild soap.
- c.* Denatured alcohol (NSN 6810-00-201-0906).
- d.* Lens tissue (NSN 5640-00-393-2090).

4-12. Organizational Monthly Preventive Maintenance Checks and Services

For organizational monthly preventive maintenance

Table 4-2. Organizational Preventive Maintenance
Monthly Checks and Services

Total task-hours required: 1.5

Sequence No.	Item to be inspected procedure	Work Time (M/H)
1	<p>COVER ASSEMBLY Inspect for tears, damaged buckles, dirt, and proper fit with cowling assembly. Clean if needed. Replace if worn or damaged. Refer to figure 1-3 for location.</p>	0.1
2	<p>SEARCHLIGHT HOUSING ASSEMBLY Clean exterior surface including nameplates; make sure that nameplates are legible. Inspect cowling latches; check to see that they close properly. Inspect blower inlet and outlet screens; remove any obstructions. Inspect heat exchanger assembly air ducts for accumulations of dirt. If needed, remove blower outlet and inlet screens; set main power switch to OFF, and flush out air ducts by pouring water into blower inlet port. Replace blower inlet and outlet screens. Refer to paragraph 3-3, 3-8b, and 4-7 for detailed procedures.</p> <p style="text-align: center;">NOTE</p> <p>Heat exchanger assembly is sealed to prevent water from entering searchlight housing assembly.</p>	0.1
3	<p>COWLING ASSEMBLY Remove and check inner gasket and outer ring; they must make a secure and watertight seal. Clean glass if needed. Replace cowling assembly and check to see that it fits properly with searchlight housing assembly. Inspect cowling latches; check to see that they close properly. Replace cowling assembly if it is damaged, not watertight, or fits improperly to searchlight housing assembly. Refer to paragraph 3-8b for detailed procedures.</p>	0.1
4	<p>INDICATOR LIGHT Inspect for dirt; clean if needed. Refer to paragraph 4-6 for detailed procedures</p>	0.1
5	<p>PRIMARY REFLECTOR Inspect for scratches or pitted surface. Clean with pure alcohol; use lens tissue or lint-free cloth.</p>	0.1
6	<p>LAMP HOUSING ASSEMBLY Inspect for cracked or broken lens, and corrosion. Refer to figure 1-5 for parts location.</p>	0.1
7	<p>CABLE ASSEMBLIES (WHERE APPLICABLE) Inspect for corrosion, stripped threads, damaged insulation, broken strands, and proper fit to receptacles; replace if needed.</p>	0.1
8	<p>SEARCHLIGHT Perform an operational check by following start, standby, and stop procedures. Place searchlight of all modes of operation and check for proper response. Inspect indicator light on control box for proper operation during overdrive mode. If lamp is defective, remove lens cap; turn it counterclockwise and replace lamp. Replace lens cap. Refer to paragraphs 3-4, 3-5, and 3-6 for operation, standby and stopping procedures. Check for completeness. Refer to appendix B for list.</p>	0.3
9	<p>MT-3900A/GSS-14(V) Turn azimuth and elevation handwheels; see that mechanical action</p>	0.1

*Table 4-2. Organizational Preventive Maintenance
Monthly Checks and Services-Continued
Total task-hours required: 1.5*

Sequence No.	Item to be inspected procedure	Work Time (M/H)
10	is smooth and free from binding. Turn elevation brake handwheel; see that elevation brake locks and releases properly. Refer to figure 3-1 for parts location. SHOCKMOUNT ASSEMBLY AN/VSS-1(V) Inspect for loose or missing hardware. Tighten any loose nuts or bolts, replace any missing components, and replace if worn or damaged. Refer to paragraph 4-15 for detailed procedures.	0.2
11	PUBLICATIONS Check to see that all publications are complete, serviceable, and current. Refer to DA Pam 310-4 for the latest changes.	0.1
12	MODIFICATIONS Check DA Pam 310-4 to determine if new applicable MWOs have been published. All URGENT MWOs must be applied immediately. All NORMAL MWOs must be scheduled. Refer to DA Pam 310-4 for the latest MWOs.	0.1

Change 1 4-4

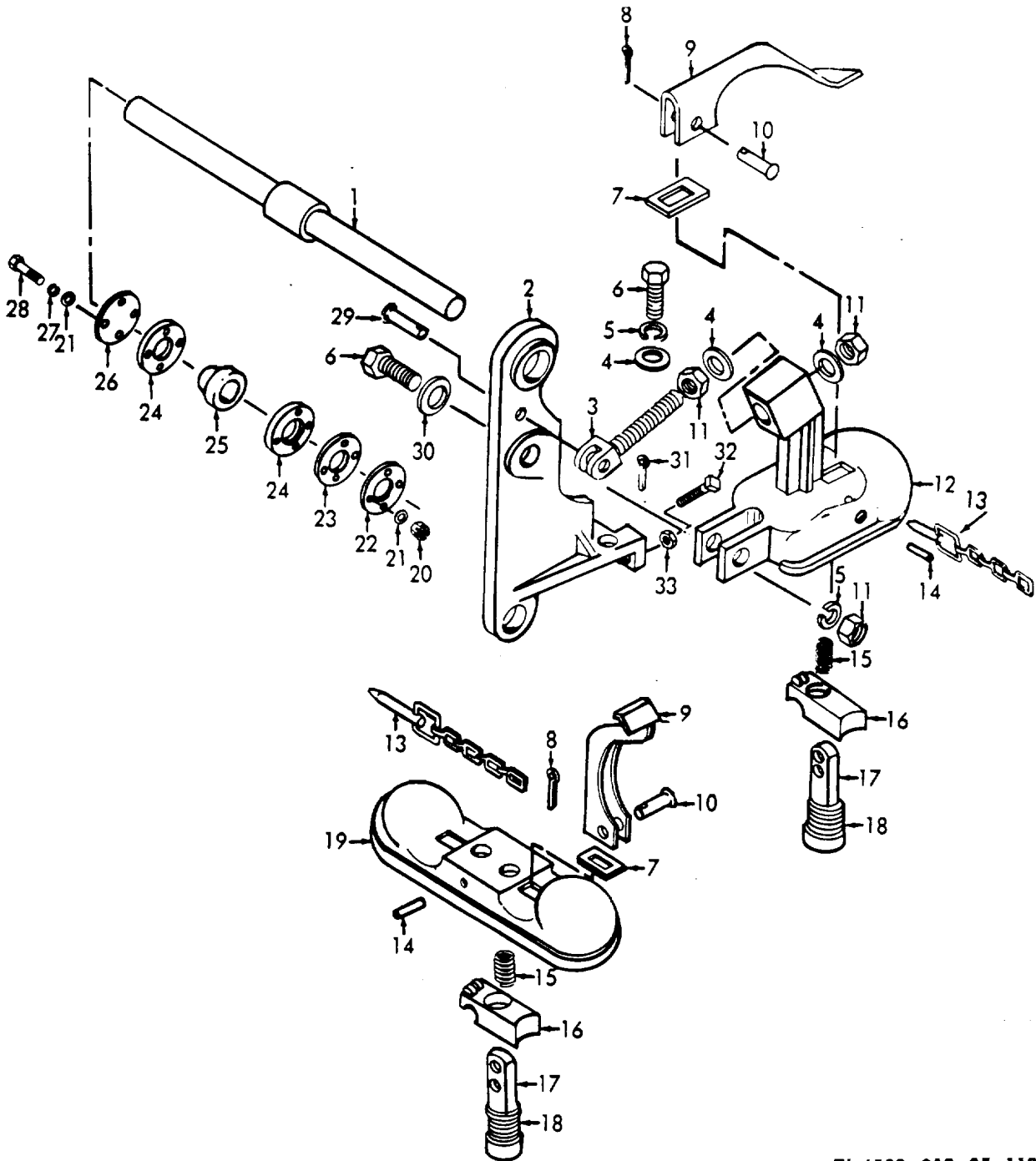

EL6230-219-35-113

Legend for fig. 4-1:

- | | | |
|------------|------------|----------------|
| 1. Rod | 11. Nut | 23. Seal |
| 2. Bracket | 12. Socket | 24. Ring |
| 3. Screw | 13. Pin | 25. Bearing |
| 4. Washer | 14. Pin | 26. Cap |
| 5. Washer | 15. Spring | 27. Lockwasher |
| 6. Bolt | 16. Lock | 28. Screw |
| 7. Plate | 17. Shaft | 29. Pin |
| 8. Pin | 18. Spring | 30. Washer |
| 9. Handle | 19. Socket | 31. Pin |
| 10. Pin | 20. Nut | 32. Setscrew |
| | 21. Washer | 33. Nut |
| | 22. Ring | |

Figure 4-1. Shockmount assembly, exploded.

Section IV. ORGANIZATIONAL SUPPORT REMOVAL AND REPLACEMENT

4-14. General

This section describes the removal and replacement of assemblies and components. Organizational support maintenance personnel are authorized to perform these procedures. Read the procedure thoroughly before removing an assembly or component.

4-15. Replacement and Repair Techniques

When mechanical parts are removed or disassembled, perform the following:

WARNING

Adequate ventilation should be provided while using TRICHLORO-TRIFLUOROETHANE. Prolonged breathing of vapor should be avoided. The solvent should not be used near heat or open flame; the products of decomposition are toxic and irritating. Since TRICHLORO-TRIFLUOROETHANE dissolves natural oils, prolonged contact with skin should be avoided. When necessary, use gloves which the solvent cannot penetrate. If the solvent is taken internally, consult a physician immediately.

- a. Clean all parts with trichlorotrifluoroethane; use a soft brush, if necessary.
- b. Remove-surface corrosion from steel parts by polishing lightly with fine crocus cloth.
- c. Allow parts to dry thoroughly before replacing.
- d. When not in use, keep all usable parts in clean, covered plastic containers or plastic bags.
- e. Inspect all parts for cracks, pits, nicks, and scratches.
- f. If parts are impractical to repair, replace with new or serviceable ones.

4-16. Disassembly and Reassembly of Shockmount Assembly

(fig. 4-1)

a. Disassembly.

- (1) Remove nut (20), washer (21), screw (28), lockwasher (27), and washer (21).
- (2) Remove cap (26) and remove shockmount assembly from searchlight.
- (3) Remove ring (22), seal (23), ring (24), and bearing (25) from rod (1).

- (4) Remove rod (1) from bracket (2).
- (5) Remove pin (31) from pin (29).
- (6) Remove nut (11), washer (5), bolt (6), and washer (30) from bracket (2).
- (7) Remove socket (12) from bracket (2).
- (8) Remove nut (11) and washer (4) from screw (3).
- (9) Remove pin (8) from pin (10) and remove handle (9), plate (7), spring (15), lock (16), shaft (17), and spring (18) from socket (12).
- (10) Remove bolt (6) and washers (5 and 4) from bracket (2).
- (11) Remove pin (8) from pin (10) and remove handle plate (7), spring (15), lock (16), pin (14), shaft (17), and spring (18) from socket (19).
- (12) Clean, inspect, and repair (para 3-26b).

b. Reassembly.

- (1) Replace spring (18), shafts (17), and pins (14) in locks (16).
- (2) Replace springs (15) on shaft (17) and place shaft (17) through slot in socket (19).
- (3) Replace plates (7) and handles (9) over shaft (17).
- (4) Secure handles (9) to shaft (17) with pins (10 and 8).
- (5) Secure socket (19) to bracket (2) with bolt (6) and washer (5 and 4).
- (6) Replace spring (18), shaft (17), and pin (14) in lock (16).
- (7) Replace spring (15) on shaft (17) and place shaft (17) through slot in socket (12).
- (8) Replace plate (7) and handle (9) over shaft (17).
- (9) Secure handle (9) to shaft (17) with pins (10 and 8).
- (10) Replace screw (3) through socket (12) and secure with washer (4) and nut (11).
- (11) Attach socket (12) to bracket (2) and secure with nut (11), washers (5 and 30), and bolt (6).
- (12) Secure screw (3) to bracket (2) with pins (29 and 31).
- (13) Replace rod (1) through bracket (2).
- (14) Replace ring (22), seal (23), ring (24), bearing (25), and ring (24).
- (15) Attach shockmount to the searchlight with cap (26), screw (28), lockwasher (27); washer (21), and nut (20).

CHAPTER 5 SHIPMENT, AND LIMITED STORAGE

5-1. Repackaging for Shipment or Limited Storage

a. General. The exact procedure for repackaging depends on the material available and the conditions under which the equipment is to be shipped or stored. Use the procedures given below whenever possible; the information covering the original packaging (para 2-1) will also be helpful.

CAUTION

When handling the searchlight take care not to damage the blower motor screens (fig. 3-2), rest or support on a level surface.

b. Tank-Mounted Searchlight (fig. 2-1 and 2-2).

(1) Cover the searchlight with the cover assembly.

(2) Remove the tank power cable from the searchlight and the tank.

(3) Remove the lockpins from the three hitch handles.

(4) Hold the searchlight in position on the mounting brackets and raise the latches. Remove the searchlight from the tank.

(5) Place the searchlight in the original (or similar) packing box and secure it.

(6) Disconnect the cables from the tank control box.

(7) Remove the tank control box by loosening the attaching hardware.

(8) Place the equipment in the packing box.

(9) Check to be sure that the equipment is complete as listed in the basic issue items list (app B).

(10) Attach the sides and top of the packing box and secure them; use nails and screws.

c. Mounted Searchlight (fig. 2-3 and 2-4).

(1) Perform the conversion for travel procedures (para 4-9).

(2) Disconnect the power cables.

(3) Position a forklift, crane, or equivalent, to support the mounted searchlight.

(4) Remove the five bolts that secure the mounted searchlight.

WARNING

Do not stand or lie under the mounted searchlight while it is supported only by the forklift, crane, or equivalent equipment. Serious injury may result.

(5) With the forklift, crane, or equivalent equipment, remove the mounted searchlight.

(6) Place the mounted searchlight on the base of the packing box and secure it; use bolts.

(7) Attach the sides and top of the packing box to the base and secure them; use nails and screws.

5-2. Limited Storage

When the searchlight is to be stored for a limited time, follow the procedures given below.

a. Be sure the equipment is serviceable. Unserviceable components should be repaired or replaced.

b. Thoroughly clean the primary reflector, the cowling assembly, and the exterior surface of the searchlight components.

c. Replace the canvas cover assembly over the front of the searchlight subassemblies.

d. Perform procedures given in paragraph 5-1 to complete the limited storage procedure.

**APPENDIX A
REFERENCES**

Following is a list of applicable references available to the operator of the searchlight:

DA Pam 310-4 TM 1-2300351-15-3	Index of Technical Publications Organizational, DS, GS, and Depot Maintenance Manual: Installation of Searchlight, Visible-Infrared AN/GSS-14 on Truck, Utility, 1/4-ton, 4 x 4, M-151A1.
TM 38-750	The Army Maintenance Management System (TAMMS).
TM 740-90-1	Administrative Storage of Equipment.
TM 750-244-2	Procedures for Destruction of Electronics Materiel to Prevent Enemy Use (Electronics Command).

Change A-1

**APPENDIX B
BASIC ISSUE ITEMS LIST, ITEMS TROOP INSTALLED OR
AUTHORIZED LIST, AND ORGANIZATIONAL MAINTENANCE
REPAIR PARTS AND SPECIAL TOOLS LISTS**

Section I. INTRODUCTION

B-1. Scope

This appendix lists basic issue items and repair parts required for operation and performance of organizational maintenance of the AN/GSS-14 (V) 1, AN/ GSS-14 (V) 2, AN/VSS-1 (V) 1, and the AN/VSS1(V)2.

B-2. General

This Basic Issue Items, Items Troop Installed or Authorized, Repair Parts and Special Tools List is divided into the following sections:

- a. *Section II. Basic Issue Items List.* A list, in alphabetical sequence, of items which are furnished with and which must be turned in with the end item.
- b. *Section III. Items Troop Installed or Authorized List.* Not applicable.
- c. *Section IV. Repair Parts List.* A list of repair parts authorized for use in the performance of maintenance. The list also includes parts which must be removed for replacement of the authorized parts. Parts lists are composed of functional groups in ascending numerical sequence, with the parts in each group listed in figure and item number sequence.
- d. *Section V. Special Tools List.* Not applicable.
- e. *Section VI. National Stock Number and Part Number Index.* Not applicable.

B-3. Explanation of Columns

The following provides an explanation of columns found in the tabular listings:

- a. *Illustration.* This column is divided as follows:
 - (1) *Figure number.* Indicates the figure number of the illustration in which the item is shown.
 - (2) *Item number.* The number used to identify each item called out in the illustration.
- b. *Source, Maintenance, and Recoverability Codes (SMR).*
 - (1) *Source code.* Source codes are assigned to support items to indicate the manner of acquiring support items for maintenance, repair, or overhaul of end items. Source codes are entered in the first and second positions of the Uniform SMR Code format as follows:

<i>Code</i>	<i>Definition</i>
PA-Item procured and stocked for anticipated or known usage.	
PD-Support item, excluding support equipment, procured for initial issue or outfitting and stocked only for subsequent or additional initial issues or outfittings. Not subject to automatic replenishment.	

<i>Code</i>	<i>Definition</i>
-------------	-------------------

(2) *Maintenance code.* Maintenance codes are assigned to indicate the levels of maintenance authorized to USE and REPAIR support items. The maintenance codes are entered in the third and fourth positions of the Uniform SMR Code format as follows:

(a) The maintenance code entered in the third position will indicate the lowest maintenance level authorized to remove, replace, and use the support item. The maintenance code entered in the third position will indicate the following level of maintenance:

<i>Code</i>	<i>Application/Explanation</i>
O-Support item is removed, replaced, used at the organizational level.	

(b) The maintenance code entered in the fourth position indicates whether the item is to be repaired and identifies the lowest maintenance level with the capability to perform complete repair (i.e., all authorized maintenance functions). This position will contain one of the following maintenance codes:

<i>Code</i>	<i>Application/Explanation</i>
F-The lowest maintenance level capable of complete repair of the support item is the direct support level.	
Z-Nonreparable. No repair is authorized.	

(3) *Recoverability code.* Recoverability codes are assigned to support items to indicate the disposition action or unserviceable items. The recoverability code is entered in the fifth position of the Uniform SMR Code format as follows:

<i>Recoverability Codes</i>	<i>Definition</i>
Z-Nonreparable item. When unserviceable, condemn and dispose at the level indicated in position 3.	
F-Reparable item. When uneconomically reparable, condemn and dispose at the direct support level.	

c. *National Stock Number.* Indicates the National stock number assigned to the item and will be used for requisitioning purposes.

d. *Part Number.* Indicates the primary number used by the manufacturer (individual, company, firm, corporation, or Government activity), which controls the design and characteristics of the item by means of its engineering drawings, specifications standards, and

inspection requirements, to identify an item or range of items. For BILL, see explanation of description column, para f.

NOTE

When a stock-numbered item is requisitioned, the repair part received may have a different part number than the part being replaced.

e. Federal Supply Code for Manufacturer (FSCM). The FSCM is a 5-digit numeric code listed in SB 708-42 which is used to identify the manufacturer, distributor, or Government agency, etc. For BILL, see explanation of description column, para f.

f. Description. Indicates the Federal item name and, if required, a minimum description to identify the item. The last line for each item in the BILL indicates the part number with the FSCM in parentheses.

g. Unit of Measure (U/M). Indicates the standard of the basic quantity of the listed item as used in performing the actual maintenance function. This measure is expressed by a two-character alphabetical abbreviation (e.g., ea, in, pr, etc.). When the unit of measure differs from the unit of issue, the lowest unit of issue that will satisfy the required units of measure will be requisitioned.

h. Quantity Furnished with Equipment (Basic Issue Items Only). Indicates the quantity of the basic issue item furnished with the equipment.

i. Quantity Incorporated in Unit. Indicates the quantity of the item used in the breakout shown on the illustration figure, which is prepared for a functional group, subfunctional group, or an assembly.

B-4. Special Information

Usable on codes are shown in the description column. Uncoded items are applicable to all models. Identification of the usable on codes used in this publication are:

<i>Code</i>	<i>Used On</i>
CRV	AN/GSS-14 (V) 1
CRW	AN/GSS-14 (V) 2
CRX	AN/VSS-1 (V) 1
CRY	AN/VSS-1 (V) 2

B-5. How to Locate Repair Parts

a. When National stock number or part number is unknown:

(1) First. Using the table of contents, determine the functional group within which the repair part belongs. This is necessary since illustrations are prepared for functional groups and listings are divided into the same groups.

(2) Second. Find the illustration covering the functional group to which the repair part belongs.

(3) Third. Identify the repair part on the illustration and note the illustration figure and item number of the repair part.

(4) Fourth. Using the Repair Parts Listing, find the figure and item number noted on the illustration.

b. When National stock number or part number is known; refer to the Repair Parts Listing.

B-6. Abbreviations

(Not applicable)

(Next printed page is B-5)

SECTION II. BASIC ISSUE ITEMS LIST

(1) ILLUSTRATION		(2) NATIONAL STOCK NUMBER	(3) DESCRIPTION		(4) QTY
A FIG. NO.	B ITEM NO.		PART NUMBER & FSCM	USABLE ON CODE	
		5855-00-012-1910	COVER ASSEMBLY SC-D-614085 (80063)		1

AMSEL-MA Form 6010
1 Oct 74

HISA-FM 2880-74

SECTION IV. REPAIR PARTS LIST

(1) ILLUSTRATION		(2)	(3)	(4)	(5)	(6) DESCRIPTION	(7)	(8)
(a) FIG NO.	(b) ITEM NO.	SMR CODE	NATIONAL STOCK NUMBER	PART NUMBER	FSCM	USABLE ON CODE	U/M	QTY INC IN UNIT
B-1	1	PAOZZ	5855-00-012-1910	SC-D-614085	80063	GROUP: 00 SEARCHLIGHT, INFRARED AN/GSS14(V)1, AN/GSS- 14(V)2, AN/VSS-1(V)1, AN/VSS-.2(V)2 COVER, CANVAS.....	EA	1
B-1	2	PAOZZ	5995-00-134-7165	SC-D-614094	80063	CABLE ASSEMBLY CX-10729CRX, CRY		
B-1	3	PAOZZ	6240-00-155-7836	MS25237-327	96906	GROUP: 01 CONTROL, SEARCHLIGHT C-7164/GSS-14(V), C- 7163/VSS-1(V) LAMP, INCANDESCENT.....	EA	1
B-1	4	PAOZZ	5920-00-681-353	FOZA25A250V	81349	GROUP: 02 MOUNT, SEARCH MT-3099AGSS- FUSECRV, CRU	EA	1
B-1	5	PAOZZ	6240-00-155-7836	MF25237-327	96906	LAMP, INCANDESCENT.....CRV CRV	EA	5
B-1	6	PDOFF	5855-00-937-5542	SC-D-614093	80063	GROUP: 04 SEARCHLIGHT ASSEMBLY GROUP: 0403 COWLING ASSEMBLY COWLING ASSEMBLY	EA	1

AMSEL-MA Form 6196
1 OCT 74

HISA-FM 2885/74

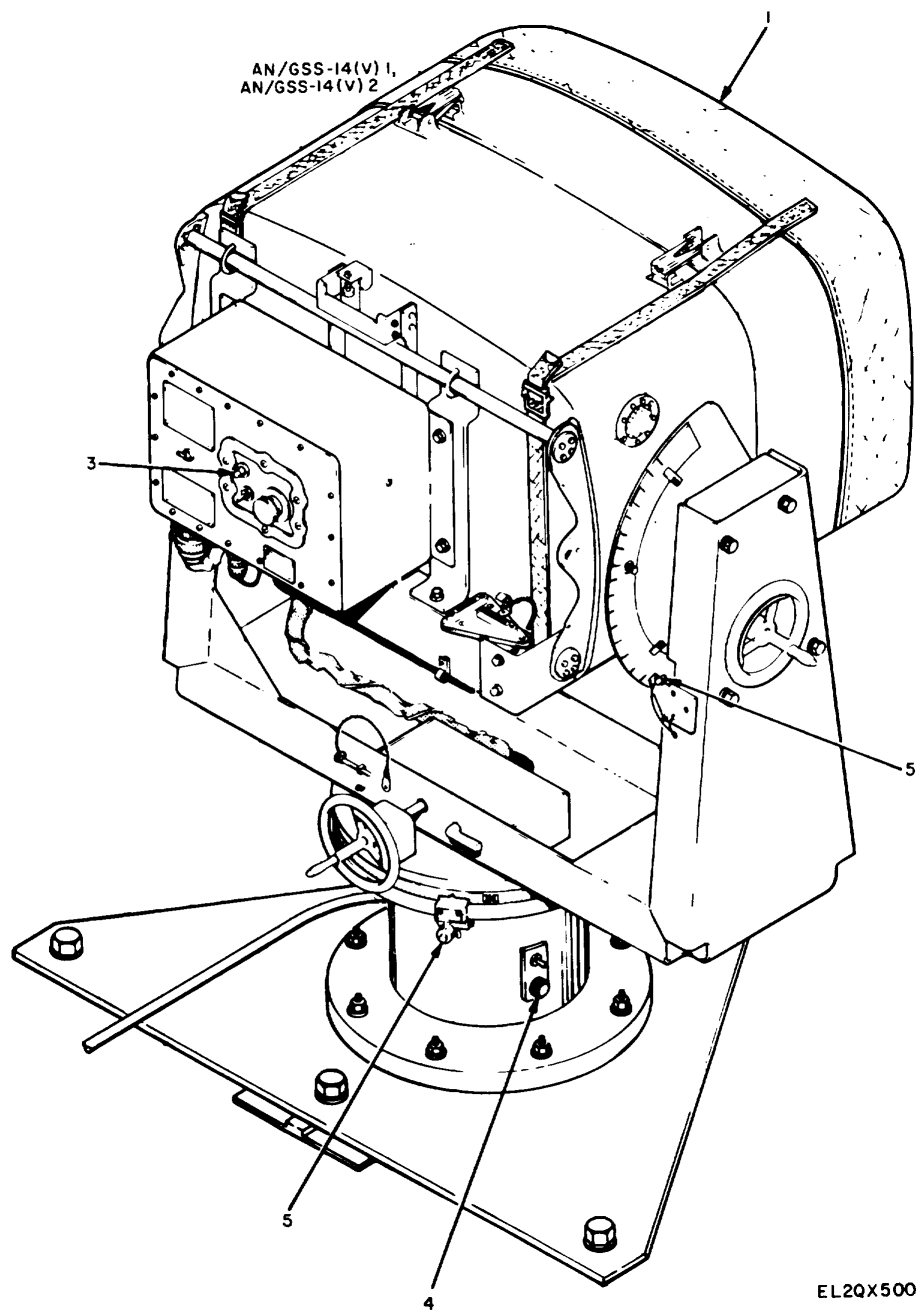
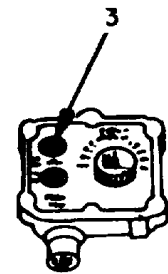
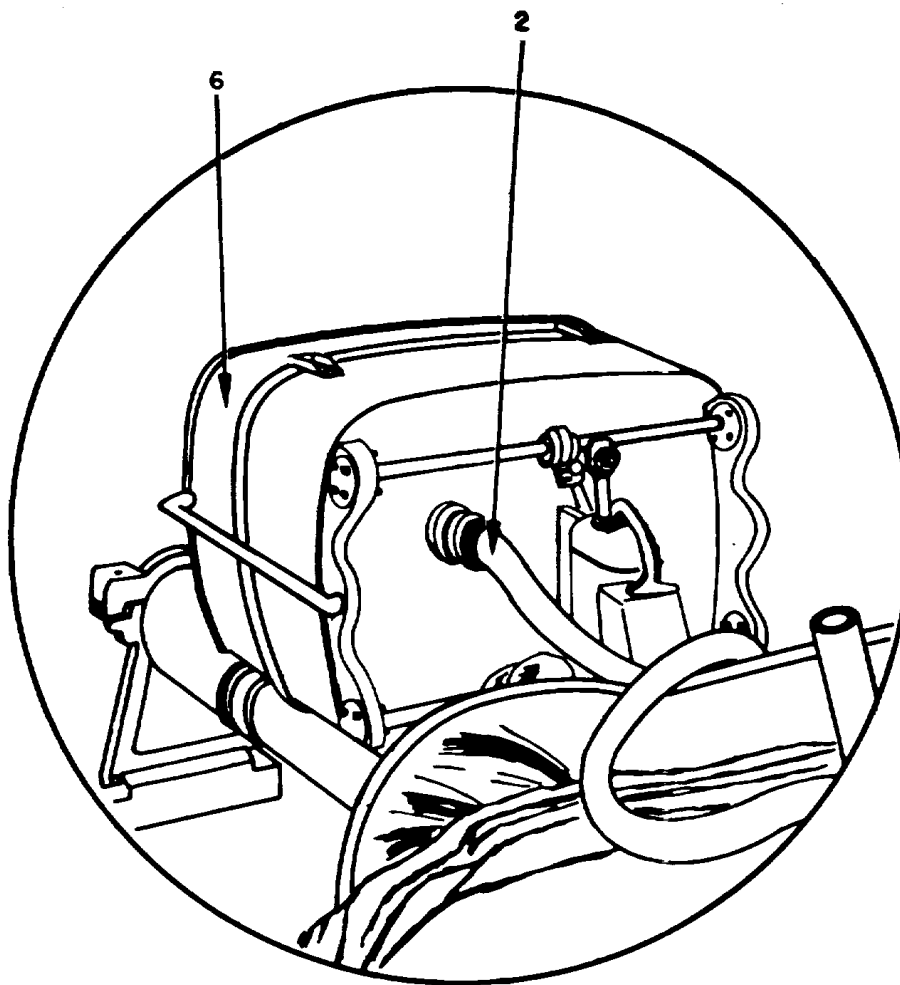

Figure B-1. Searchlight, Infrared AN/GSS- 14(V), AN/GSS-14(V)2, AN/VSS-1(V)1, and AN/VSS-1(V)2 (sheet 1 of 2).



AN/VSS-1(V) 1,
AN/VSS-1(V) 2

EL2QX50I

Figure B-1. Searchlight, Infrared AN/GSS- 14(V)1, AN/GSS-14(V)2, AN/VSS- 1(V)1, and AN/VSS-1(V)2 (sheet 2 of 2).

APPENDIX C MAINTENANCE ALLOCATION

Section I. INTRODUCTION

C-1. General.

This appendix provides a summary of the maintenance operations for the AN/GSS-14(V)1, AN/GSS-14(V)2, AN/VSS-1(V)1, and the AN/VSS-1(V)2. It authorizes categories of maintenance for specific maintenance functions on repairable items and components and the tools and equipment required to perform each function. This appendix may be used as an aid in planning maintenance operations.

C-2. Maintenance Function.

Maintenance functions will be limited to and defined as follows:

a. Inspect. To determine the serviceability of an item by comparing its physical, mechanical, and/or electrical characteristics with established standards through examination.

b. Test. To verify serviceability and to detect incipient failure by measuring the mechanical or electrical characteristics of an item and comparing those characteristics with prescribed standards.

c. Service. Operations required periodically to keep an item in proper operating condition, i.e., to clean (decontaminate), to preserve, to drain, to paint, or to replenish fuel, lubricants, hydraulic fluids, or compressed air supplies.

d. Adjust. To maintain, within prescribed limits, by bringing into proper or exact position, or by setting the operating characteristics to the specified parameters.

e. Align. To adjust specified variable elements of an item to bring about optimum or desired performance.

f. Calibrate. To determine and cause corrections to be made or to be adjusted on instruments or test measuring and diagnostic equipments used in precision measurement. Consists of comparisons of two instruments, one of which is a certified standard of known accuracy, to detect and adjust and discrepancy in the accuracy to the instrument being compared.

g. Install. The act of emplacing, seating, or fixing into position an item, part, module (component or assembly) in a manner to allow the proper functioning of the equipment or system.

h. Replace. The act of substituting a serviceable like type part, subassembly, or module (component or assembly) for an unserviceable counterpart.

i. Repair. The application of maintenance services

(inspect, test, service, adjust, align, calibrate, replace) or other maintenance actions (welding, grinding, riveting, straightening, facing, remachining, or resurfacing) to restore serviceability to an item by correcting specific damage, fault, malfunction, or failure in a part, subassembly, module (component or assembly), end item, or system. This function does not include the trial and error replacement of running spare type items such as fuses, lamps, or electron tubes.

j. Overhaul. That maintenance effort (service/action) necessary to restore an item to a completely serviceable/operational condition as prescribed by maintenance standards (i.e., DMWR) in appropriate technical publications. Overhaul is normally the highest degree of maintenance performed by the Army. Overhaul does not normally return an item to like new condition.

k. Rebuild. Consists of those services/actions necessary for the restoration of unserviceable equipment to a like new condition in accordance with original manufacturing standards. Rebuild is the highest degree of materiel maintenance applied to Army equipment. The rebuild operation includes the act of returning to zero those age measurements (hours, miles, etc.) considered in classifying Army equipment/components.

C-3. Column Entries.

a. Column 1, Group Number. Column 1 lists group numbers, the purpose of which is to identify components, assemblies, subassemblies, and modules with the next higher assembly.

b. Column 2, Component/Assembly. Column 2 contains the noun names of components, assemblies, subassemblies, and modules for which maintenance is authorized.

c. Column 3, Maintenance Functions. Column 3 lists the functions to be performed on the item listed in column 2. When items are listed without maintenance functions, it is solely for purpose of having the group numbers in the MAC and RPSTL coincide.

d. Column 4, Maintenance Category. Column 4 specifies, by the listing of a "work time" figure in the appropriate subcolumn(s), the lowest level of maintenance authorized to perform the function listed in column 3. This figure represents the active time required to perform that maintenance function at the indicated

category of maintenance. If the number or complexity of the tasks within the listed maintenance function vary at different maintenance categories, appropriate "work time" figures will be shown for each category. The number of task-hours specified by the "work time" figure represents the average time required to restore an item (assembly, subassembly, component, module, end item or system) to a serviceable condition under typical field operation conditions. This time includes preparation time, troubleshooting time, and quality assurance/quality control time in addition to the time required to perform the specific tasks identified for the maintenance functions authorized in the maintenance allocation chart, Subcolumns of column 4 are as follows:

- C-Operator/Crew
- O-Organizational
- F-Direct Support
- H-General Support
- D-Depot

e. Column 5, Tools and Equipment. Column 5 specifies by code, those common tool sets (not individual

tools) and special tools, test, and support equipment required to perform the designated function.

C-4. Tool and Test Equipment (Table 1).

a. Tool or Test Equipment Reference Code. The numbers in this column coincide with the numbers used in the tools and equipment column of the MAC. The numbers indicate the applicable tool or test equipment for the maintenance functions.

b. Maintenance Category. The codes in this column indicate the maintenance category allocated the tool or test equipment.

c. Nomenclature. This column lists the noun name and nomenclature of the tools and test equipment required to perform the maintenance functions.

d. National/NATO Stock Number. This column lists the National/NATO stock number of the specific tool or test equipment.

e. Tool Number. This column lists the manufacturer's part number of the tool followed by the Federal Supply Code for manufacturers (5-digit) in parentheses.

SECTION II MAINTENANCE ALLOCATION CHART
FOR

SEARCHLIGHT, INFRARED AN/VSS-1(V)1, AN/VSS-1(V)2, AR/GSS-14(V)1 AND AN/GSS-14(V)2

(1) GROUP NUMBER	(2) COMPONENT ASSEMBLY	(3) MAINTENANCE FUNCTION	(4) MAINTENANCE CATEGORY					(5) TOOLS AND EQUIPMENT	(6) REMARKS
			C	O	F	H	D		
00	SEARCHLIGHT, INFRARED AN/GSS-14(V)1 AN/GSS-14(V)2, AN/VSS-1(V)1, AND AN/VSS-1(V)2	Inspect	0.3						
		Inspect		0.7					
		Service	0.5	0.6					
		Service		0.5					
		Replace			1.0			1 thru 4, 6 thru 9	
		Test			2.0			2,3,4, 6 thru 9	
		Replace			4.0			1 thru 4, 6 thru 9	
		Repair				4.0		1 thru 4, 6 thru 9	
		Repair					24.0	1 thru 9	
		Overhaul							
01	CONTROL SEARCHLIGHT C-7164/GSS-14(y) OR C-7163/VSS-1(V)	Inspect		0.1					
		Inspect		0.1					
		Repair			0.2				A
	Repair				2.0		1,4,9		
02	MOUNT, SEARCHLIGHT M,-3900/GSS-14(V) USED ON AN/GSS-14(V) ONLY) OR MOUNT, SEARCHLIGHT MT-3900A/GSS-14(V) USED ON AN/GSS-14(V) ONLY)	Inspect	0.1					1,4,9	
		Inspect		0.1					
	Repair			2.0			1,4,9		
0201	YOKE ASSEMBLY	Repair			1.8			4,9	
020101	AZIMUTH GEAR BOX ASSEMBLY (USED ON MT-3900A/GSS-14(V))	Repair			1.6			4,9	
020102	BRAKE ASSEMBLY (USED ON MT-3900A/GSS-14(V) ONLY)	Repair			1.3			4,9	
02010201	PLATE ASSEMBLY (USED ON MT-3900A/GSS-14(V) ONLY)	Repair			1.3			4,9	
020103	ELEVATION GEAR BOX ASSEMBLY (USED ON MT-3900A/GSS-14(V) ONLY)	Repair			1.3			4,9	
02010301	PLATE ASSEMBLY (USED ON MT-3900A/GSS-14(V) ONLY)	Repair			1.3			4,9	
0202	PEDESTAL ASSEMBLY	Repair			1.0			4,9	
0203	SHOCK ABSORBER (USED ON MT-3900/GSS-14(V) ONLY)	Repair			1.0			4,9	
0204	BRACKET ASSEMBLY (USED ON MT-3900/GSS-14(V) ONLY)	Repair			0.7			4,9	
03	SHOCK MOUNT ASSEMBLY (USED ON AN/VSS-1(V) ONLY)	Repair			1.5			4,9	
0301	HITCH ASSEMBLY, UPPER	Replace		1.0				4,9	C
0302	HITCH ASSEMBLY, LOWER	Replace		1.0				4,9	C
04	SEARCHLIGHT SUBASSEMBLY	Inspect	0.1						
		Service	0.2						
		Adjust			1.0				1 thru 4, 6 thru 9
		Test			1.0				1 Thru 4., 6,7
		Replace		0.2					
	Repair			3.0				1 thru 4, 6 thru 9	
	Repair				2.0			4,9	
0401	GEAR MOTOR DRIVE ASSEMBLY	Repair			1.5			2,3,4, 6 thru 9	
0402	CONVERTER ASSEMBLY, MODEL 6484, MODEL 9912, MODEL 9924, MODEL 9948, AND MODEL F50001	Repair			1.5			2,3,4, 6	
		Repair			2.5		thru 9	1 thru 4, 6 thru 9	
0403	COWLING ASSEMBLY	Replace		0.3.				4,9	
	Repair			0.8				1 thru 4, 6 thru 9	
0404	HEAT EXCHANGER	Repair			2.3				

SECTION II MAINTENANCE ALLOCATION CHART

FOR

SEARCHLIGHT, INFRARED AN/VSS-1(V)2, AN/VSS-1(V)2, AN/GSS-14(V)1 AND AN/GSS-14(V)2

(1) GROUP NUMBER	(2) COMPONENT ASSEMBLY	(3) MAINTENANCE FUNCTION	(4) MAINTENANCE CATEGORY					(5) TOOLS AND EQUIPMENT	(6) REMARKS
			C	O	F	H	D		
0401	LOWER MOTOR ASSEMBLY	Repair			1.6			1 thru 4, 6 thru 9	
		Repair				1.4		1 thru 4, 6 thru 9	
0405	HOUSING SUBASSEMBLY	Repair			1.8			1 thru 4, 6 thru 9	
0405	LAMP HOUSING ASSEMBLY	Replace			1.2			1 thru 4, 6 thru 9	
		Repair				2.1		4,9	
0407	IGNITER ASSEMBLY	Replace			1.8			1 thru 4, 6 thru 9	
0408	SCOPE MOUNT ASSEMBLY	Repair			0.6			9	
0409	RELAY PANEL ASSEMBLY, MODEL 9913 (USED ON AN/VSS-1(V) ONLY) OR MODEL SC-D-613960	Repair			1.2			1 thru 4, 6 thru 9	
		Repair			0.7			1 thru 4, 6 thru 9	
0410	SWITCH ASSEMBLY	Repair			0.6			1,4,9	
05	180-AMPERE ALTERNATOR KIT (USED WITH AN/GSS-14(V)) (REFER TO TM 11-2300-351-13)	Replace			1.0			4,9	
0501	MOUNTING KIT (USED WITH AN/GSS-4(V)) (REFER TO TM 11-2300-351-15-3)	Replace		1.0		4.9			
06	CABLE ASSEMBLIES (USED WITH AN/GSS-14(V)) (REFER TO TM 11-2300-351-15-3)	Replace			1.0			4,9	

TABLE 1. TOOL AND TEST EQUIPMENT REQUIREMENTS
 FOR
 SEARCHLIGHT, INFRARED AN/VSS-1(V)1, AN/VSS-1(V)2, AN/GSS-14(V)1, AND AN/GSS-14(V)2

(1) TOOL OR TEST EQUIPMENT REF CODE	(2) MAINTENANCE LEVEL	(3) NOMENCLATURE	(4) NATIONAL/NATO STOCK NUMBER	(5) TOOL NUMBER
1	F, H, D	MULTIMETER TS-352B/U (IF TEST SET, SEARCHLIGHT AN/GSM219 IS AVAILABLE, IT SHOULD ALSO BE USED.)	6625-00-553-0142	
2	F, H, D	PLIERS, RETAINING RING	5120-00-595-9549	
3	F, H	POWER SUPPLY PP-4606/G	6130-00-947-9670	
4	F, H, D	TOOL KIT, ELECTRONIC EQUIPMENT TK-100/G	5180-00-605-0079	
5	D	TEST SET AN/GSM-184	6625-00-933-9485	
6	F, H, D	FACE SHIELD	4240-00-965-1269	
7	F, H, D	GLOVES	8415-00-564-5191	
8	F, H, D	LEATHER APRON	8415-00-234-9254	
9	F, H, D	TOOL KIT, ELECTRONIC EQUIPMENT TK-105/G	5180-00-610-8177	

SECTION IV. REMARKS

REFERENCE CODE	REMARKS
<p>A B C</p>	<p>INDICATOR LAMPS. COWLING ASSEMBLY. USE TOOLS P/O VEHICLE.</p>

RECOMMENDED CHANGES TO EQUIPMENT TECHNICAL PUBLICATIONS



THEN... JOT DOWN THE DOPE ABOUT IT ON THIS FORM, CAREFULLY TEAR IT OUT, FOLD IT AND DROP IT IN THE MAIL!

SOMETHING WRONG WITH THIS PUBLICATION?

FROM: (PRINT YOUR UNIT'S COMPLETE ADDRESS)

DATE SENT

PUBLICATION NUMBER

PUBLICATION DATE

PUBLICATION TITLE

BE EXACT... PIN-POINT WHERE IT IS

PAGE NO.	PARA-GRAPH	FIGURE NO.	TABLE NO.

IN THIS SPACE TELL WHAT IS WRONG AND WHAT SHOULD BE DONE ABOUT IT:

TEAR ALONG PERFORATED LINE

PRINTED NAME, GRADE OR TITLE, AND TELEPHONE NUMBER

SIGN HERE:

DA FORM 2028-2
1 JUL 79

PREVIOUS EDITIONS ARE OBSOLETE.

P.S.—IF YOUR OUTFIT WANTS TO KNOW ABOUT YOUR RECOMMENDATION MAKE A CARBON COPY OF THIS AND GIVE IT TO YOUR HEADQUARTERS.

PIN: 015020-000